

Excavation at LA 115266: A Coalition Period Fieldhouse Site

Charles A. Hannaford



**Museum of New Mexico
Office of Archaeological Studies**

**Archaeology Notes 263
2000**

MUSEUM OF NEW MEXICO

OFFICE OF ARCHAEOLOGICAL STUDIES

EXCAVATION AT LA 115266: A COALITION PERIOD FIELDHOUSE SITE

Charles A. Hannaford

with contributions by
Jessica Badner
C. Dean Wilson

Submitted by
Timothy Maxwell
Principal Investigator

ARCHAEOLOGY NOTES 263

ADMINISTRATIVE SUMMARY

Between February 1 and February 18, 1999 the Office of Archaeological Studies, Museum of New Mexico, conducted a data recovery program at LA 115266, Santa Fe County, New Mexico. The data recovery program was conducted at the request of the New Mexico State Highway and Transportation Department (NMSHTD) to recover important archaeological information from cultural deposits within an area of planned improvements to U.S. 285. The data recovery program followed the procedures included in the previously approved *Archaeological Testing Results from LA 115266 and LA 115268 and a Data Recovery Plan for LA 115266* (Post 1999).

LA 115266 is a multicomponent site consisting of an unknown prehistoric thermal feature, a Coalition Period pit structure and five associated extramural features, and an unknown historic stone-ringed hearth. The data recovery program focused on the Coalition period component. Site elements consisted of a small pit structure with an informal hearth and a mealing station, an extramural remodeled posthole suggesting the presence of a ramada, a shallow pit interpreted as a storage facility, and three miscellaneous pits. The artifact assemblage included 24 chipped stone artifacts, 3 ground stone artifacts, 185 sherds, and 18 faunal fragments. The site was occupied seasonally by a mixed-gender household farming the Cañada de los Alamos floodplain. The duration of the occupation was probably eight to ten seasons based on the expected use-life of the pit structure and the breakage rates for the ceramic vessels. The site served as an intermittently utilized fieldhouse associated with the nearby contemporary village of Pueblo Alamo.

The data recovery program has retrieved a representative sample of the range of features and artifacts characterizing the prehistoric occupation. The excavation has determined that the site area overlapping the proposed right-of-way is not likely to yield information beyond that already documented. No further archaeological investigations within the construction zone are recommended.

MNM Project 41.674, U.S. 285, Eldorado Excavation
NMSHTD Project No. NH-285-5(11)287, CN 2981 and NH-285-5(12)284, CN 3275
Statewide Archaeological Service Contract No. 03783
Archaeological Excavation Permit SE-137

CONTENTS

Administrative Summary	ii
Introduction	1
Environment	3
Archaeological Background	7
Excavation Results	15
Condition	16
Field Methods	16
Surface Collection	17
Stratigraphy	18
Cultural Features	20
Material Culture	31
Faunal Assemblage	31
Ground Stone Assemblage	33
Chipped Stone Artifacts by Jessica Badner	33
Ceramics by C. Dean Wilson	41
Research Questions	51
Chronology	51
Settlement	52
Discussion	54
References Cited	57
Appendix 1. General Chipped Stone Analytical Methods	63
Appendix 2. Clay Samples Collected from the Eldorado Area.	67
Appendix 3. Site Location and Legal Description	69

Figures

1. Project vicinity map	2
2. Overview of main site area	15
3. LA 115266, site map	17
4. Pit Structure 1, plan and profile	22
5. Pit Structure 1, catchment basin	24
6. Pit Structure 1, overview	24
7. Stone-ringed hearth (Feature 1) built over Pit Structure 1	26
8. Extramural Feature 2, storage facility	26
9. Plan and profile of storage facility, Feature 2	27
10. Plan and profile of Feature 3, posthole	27
11. Feature 4, pit, plan and profile	28

12. Feature 5, posthole, plan and profile	28
13. Feature 6, pit, plan and profile	29

Tables

1. Recorded site components on the Seton Village and Glorieta quadrangles	8
2. Anasazi site types and features	10
3. Artifact frequency by grid and level	19
4. Artifact types by major provenience	31
5. LA 115266 faunal assemblage	32
6. Chipped stone artifacts and material types by provenience	36
7. Chipped stone artifact morphology and material type	37
8. Chipped stone tools	38
9. Ceramic type by excavation unit	43
10. Distribution of temper by ware	43
11. Distribution of vessel form by ware	44
12. Hue color category of refired samples	45

INTRODUCTION

At the request of Mr. F. Craig Conley, Environmental Program Manager, New Mexico State Highway and Transportation Department, a data recovery program was conducted on the portion of LA 115266 within the proposed construction zone of improvements to U.S. 285, Santa Fe County, New Mexico (NMSHTD Project No. NH-285-5[11]287, CN 2981 and NH-285-5[12]284, CN 3275; Statewide Archaeological Service Contract No. 03783; Fig. 1). LA 115266 is located along the west right-of-way of U.S. 285, about 1.4 miles south of Interstate 25 and 60 m south of the second entrance to Eldorado. The site is between centerline stations 19+000 and 19+100 on the highway plans. Exact site location information is contained in Appendix 3 (removed from copies in general circulation). LA 115266 is on land controlled by the New Mexico State Highway and Transportation Department. Fieldwork took place between February 1 and February 18, 1999, conducted by Charles A. Hannaford, assisted by Jessica Badner, Bob Greene, and Sam Sweesy. A total of 51 person-days were expended during the three-week field phase. Tim Maxwell was principal investigator. Maps were drafted by Ann Noble and the report was edited by Robin Gould.

The data recovery program followed the procedures included in the previously approved *Archaeological Testing Results from LA 115266 and LA 115268 and a Data Recovery Plan for LA 115266*, Office of Archaeological Studies Archaeology Notes 243. The data recovery program was conducted under Archaeological Excavation Permit SE-137.

Before the fieldwork, the *National Register of Historic Places* and the *State Register of Cultural Properties* were consulted. No properties listed on, nominated to, or approved for submission to either inventory are located within the proposed project boundaries.

This report complies with the provisions of the Historic Preservation Act of 1966 as amended.

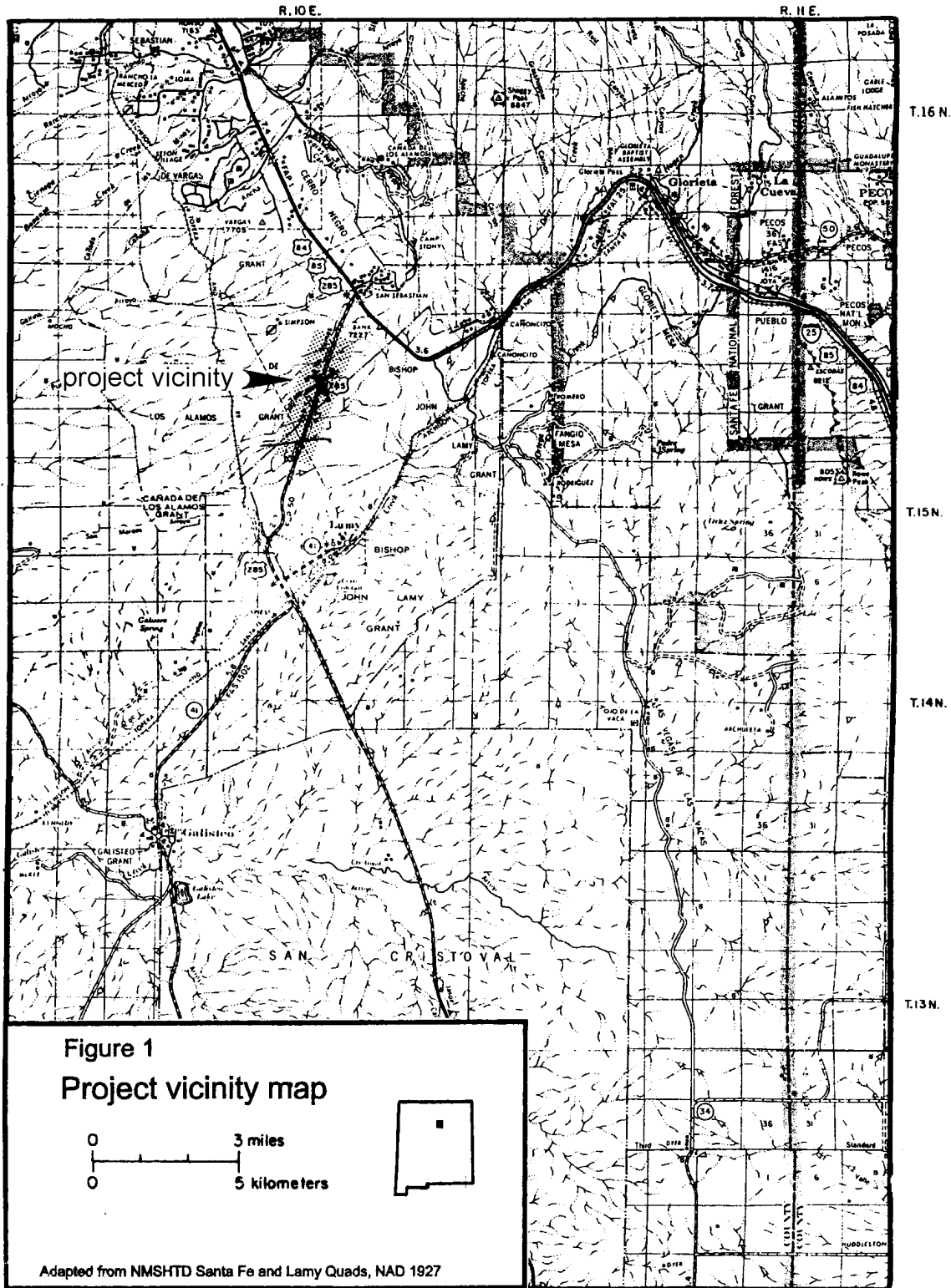

ENVIRONMENT

Archaeological investigations at Arroyo Hondo, located about 9 miles north of LA 115266, produced detailed overviews of regional physical and biological environments (Kelley 1980; Rose et al. 1981). The reader is referred to these references for comprehensive environmental discussions relevant to the project area. More immediate archaeological investigations (Lang 1992) in the Dos Griegos subdivision immediately north of the project summarize identical environmental attributes. Post (1999) summarizes the local physical environment in the data recovery plan for the project. The New Mexico State Engineers Office (SEO) contains reports of more than 20 geologists, geophysicists, hydrologists, and engineers that have been involved with evaluating the geology and hydrology of the immediate area in relation to subdivision growth in Santa Fe County (Grant 1997:3). These reports provide additional environmental overviews of the project area.

The project lies on a gentle slope extending from the west flank of the Sangre de Cristo Mountains, slightly northwest of the region where this southern extension of the Rocky Mountain's backbone plunges beneath the Glorieta Mesa to merge with the Great Plains (Grant 1997:1). The immediate topography is characterized by the interface of two contrasting physiographic units. These units consist of the sharply rising foothills of the Sangre de Cristo Mountains and the rolling flatlands of the west-trending piedmont slope.

The foothills section rises to an elevation of (7,450 ft) just east of the site. These uplands provided a rugged hinterland more conducive to prehistoric hunting and resource acquisition than farming. The area is currently viewed as a wilderness area in relation to the nearby subdivisions developing on the piedmont slope. The steep slopes contain shallow rocky soils and bedrock exposures of Precambrian granite, quartz, gneiss, schist, and diabase. The foothills are covered by rather dense growths of piñon and juniper woodland with patches of ponderosa pine and scrub oak. The crests of the foothills provide panoramic vistas of the surrounding territory. The piñon-juniper uplands had 135 of 271 plant species within the Arroyo Hondo pueblo catchment (Kelley 1980:60). Of these, 63 species are edible or have medicinal qualities. The woodland is also home to a wide range of animal species including deer.

While the foothills are composed of metamorphic rock outcrops, broken mesa country 2 miles east of the site contains complex sedimentary outcrops including limestones and shales of Pennsylvanian age, sandstones and shales of Permian and Triassic age, and sandstones and shales of Cretaceous age (Veneklasen 1983:2). Additional sedimentary rock including siltstones and conglomerates of Tertiary Eocene age are exposed along the escarpment and breaks overlooking Galisteo Creek 3 miles south of the site. Metamorphic and sedimentary materials suitable for both ground stone and chipped stone technologies are potentially available in the nearby foothills environment.

The piedmont section abuts the foothills at about the 7,100 ft level. Site elevation is 7,000 ft. The piedmont surface, called the Plains surface, slopes toward the southwest at a grade approximating 100 to 120 vertical feet per mile (Veneklasen 1983:1). The Ancha Formation covers much of the piedmont and is the predominant surface geologic feature in this section (Kelley 1980:19). The Ancha Formation completely covers earlier sedimentary and metamorphic formations and consists of silt, sand, and gravel to depths of 100 to 300 ft. The local Ancha Formation contains abundant reworked cobbles primarily of metamorphic origin. The piñon and juniper woodland covering the piedmont is interspersed with open grassland meadows. The woodlands tend to decrease and the grasslands increase with the westward declining elevation. Pronghorn are still spotted in the open

grasslands in the area. Jackrabbits and cottontails are common smaller mammals.

LA 115266 sits on the east terrace of the Cañada de los Alamos. Today, the Cañada de los Alamos is down-cut over 1 m below the old floodplain and only rarely carries seasonal surface flow during the late winter runoff. The arroyo heads in the foothills about 5 miles north of the site and drains about 6 sq miles lying between elevations of 7,400 and 8,000 ft (Grant 1997:3). In addition to springs in the upper stretches and the potential for arable land, the arroyo system provides a natural travel route across the landscape. The arroyo flows southwest and joins with San Marcos arroyo about 4 miles south of the site. San Marcos Arroyo flows past San Marcos Pueblo a few miles west of this junction and ultimately joins with Galisteo Creek, the largest stream south of Santa Fe. Galisteo Creek flows into the Rio Grande at Santo Domingo. Galisteo Creek, which at Lamy is about 3 miles south of the site, drains about 25 sq miles in the Sangre de Cristos between elevations of 7,400 and 10,200 ft (Grant 1997: 3). This substantial drainage is another potential water source. LA 115266 is roughly equidistant between Galisteo Creek and perennial springs in the upper Cañada de los Alamos. Additional springs are found at Pueblo Wells in Canyon Ancho 1 km west of Pueblo Alamo. The spring supported Chamisa Locita (LA 4), another large Coalition period pueblo. A windmill currently taps the spring and the water is used for grazing purposes.

Historically, the Cañada de los Alamos was spring fed and perennial in its upper foothill stretches. This is the location of the small village of Cañada de los Alamos founded around 1875 (Post 1994:26). The large Coalition period site of Pueblo Alamo (LA 8) is positioned where the arroyo exits the foothills. Considering the size of Pueblo Alamo, the channel probably had a perennial flow during the occupation. At the very least, a slight increase in the springs upstream or increased rainfall could easily have extended the perennial flow down to the site (Warren 1971). Two ponds dug into the channel about one-half mile above Pueblo Alamo currently contain water. There is also indication that additional springs may have been present at Pueblo Alamo. Bridge construction at this locality in the 1960s encountered the water table at 9 ft below the surface. The water table is currently lowered by subdivision growth in the area. The distance south from Pueblo Alamo where water originally flowed before sinking into the sandy floodplain is unknown. However, with a higher water table, shallow water percolating below the surface of the channel may have been easily reached by trenching and may have additionally sustained and encouraged crop cultivation for some distance.

The general soil map of Santa Fe County places the project area in the Panky-Pojoaque-Harvey soil association (Maker et al. 1971:14-15, 22). Panky soils occupy the broad, gently sloping areas between drainages. The surface layer is a thin layer of fine brown sandy loam and the subsoil is an 18- to 24-inch-thick reddish brown heavy clay loam. More detailed soil maps show that the piedmont terrain surrounding the drainage consists specifically of Silver-Pojoaque association, undulating soils (Folks 1975:47). Silver loam occurs mainly on slopes of 1 to 5 percent. Pojoaque clay loam makes up 30 percent of the association and occurs on 5 to 9 percent slopes. These soils are currently not considered suitable for dry farming.

The Cañada de los Alamos floodplain consists of Fivemile loam soil (Folks 1975:25). The soil is characterized by well-drained mixed alluvium on level to gently sloping flood plains. The soil has water holding capacity of 11 to 12 inches and an effective rooting depth of 60 inches. The soils are currently not considered suitable for dry-land farming (Folks 1975: 62), but under optimum moisture conditions the drainage terraces have sustained agriculture in both prehistoric and historic times (Kelley 1980:78). The floodplain currently supports a shrub community consisting of rabbit brush, currant, big sagebrush, wolfberry, and four-wing saltbush.

The project area has a semiarid climate. Historically, annual precipitation averaged 36 cm (14.4 inches), which is adequate for dry farming of corn and beans (Kelley 1980:29). Most of the

precipitation occurs as intense summer thunderstorms that can produce severe runoff. The foothills tend to receive more rain (and snow) than the piedmont slope and rains in the foothill catchment basins can produce unexpected high-energy flash floods in the lower piedmont floodplains. This was undoubtedly a reoccurring hazard faced by prehistoric floodplain farmers. The growing season ranges from 130 to 220 days and averages 170 days. The last spring frost usually occurs in the first week of May, and the first fall frost occurs around the middle of October.

ARCHAEOLOGICAL BACKGROUND

Dickson (1979), Viklund and Scheick (1989), Lang (1992), and Marshall (1998) provide comprehensive archaeological overviews of the region. Post (1999:5-7) specifically documents the Pueblo period background relevant to the project area. The following background section concentrates on local Anasazi land use and settlement, providing a context for the LA 115266 occupation.

The author used the New Mexico Cultural Resources Information System (NMCRIS) in a records search of the Seton Village and Glorieta 7.5' quadrangles surrounding the project area (Tables 1 and 2). The quadrangles each contain 38,648 acres and provide area coverage of both the foothill and piedmont topographic sections. The Seton Village quadrangle is characterized by a survey coverage of about 6,000 acres or 16 percent of the quadrangle. The 53 projects recorded 67 sites with a site density of about 1 site per 89 acres. The Glorieta quadrangle has survey coverage of about 5,300 acres or about 14 percent of the quadrangle. The 52 projects recorded 64 sites with a density of about 1 site per 82 acres. Projects on both quadrangles are represented mainly by subdivision surveys ranging in size from 1 to over 500 acres.

The quadrangles show almost continuous land use beginning with the Early-Middle Archaic and extending to recent homesteading and cattle ranching. Anasazi components account for 40 percent ($n = 77$) of the recorded resources, and represent the highest cultural utilization of the area. Within the Anasazi category, 85 percent ($n = 65$) of the components are coded as dating from P II/III (A.D. 900-1300) to P IV (A.D. 1300-1600). These codings suggest temporal components that may overlap the LA 115266 occupation. Unfortunately, inconsistent use of Coalition and Classic period codings prevents correlation of the components with these specific temporal designations.

The Seton Village quadrangle has both the highest frequency and the widest range of Anasazi site types and features (Table 2). Site types range from the important residential complexes of Arroyo Hondo (LA 12), Pueblo Alamo (LA 8), and Chamisa Locita (LA 4) to small, special-use artifact scatters. Residential occupations are represented by an additional 13 components with architecture consisting of roomblocks/mounds ($n = 9$) and pithouse/depressions ($n = 4$). Three smaller isolated rooms may represent fieldhouse occupations. Hilltop shrines are associated with the three larger residential complexes. Various smaller artifact scatters, some with apparent hearths, most likely represent short-term resource acquisition sites. The four garden plots recorded in the area of the Santa Fe Community College are problematic identifications and are more correctly viewed as indeterminate rock alignments.

Fewer Anasazi components with a narrower range of site types and features are recorded on the Glorieta quadrangle. Residential occupations are limited to only four sites with visible architecture in the form of roomblocks. Of these, three roomblocks are ambiguous and are recorded within the unknown site type category. The remaining roomblock/mound is a small fieldhouse located against the foothills about 3 km southwest of LA 115266. Small artifact scatters representing short-term resource procurement sites are the most prevalent Anasazi site type.

LA 115266 is surrounded by three larger subdivision surveys that provide a glimpse into immediate prehistoric land use. The Ridges subdivision encompassed a 424-acre survey of piedmont slope and foothills terrain immediately east of U.S. 285 (Viklund and Scheick 1989a). The survey recorded 2 prehistoric sites and 32 isolated occurrences. The isolated occurrences consisted mainly

Table 1. Recorded Site Components on the Seton Village and Glorieta Quadrangles

CULTURE AND PERIOD	SETON VILLAGE QUAD	GLORIETA QUAD	TOTAL	
			NUMBER	PERCENT
ARCHAIC (5500 B.C.-A.D. 900)				
Early Archaic (5500-3000 B.C.)		1	1	.5
Middle Archaic (3000-1800 B.C.)	1	2	3	1.5
Late Archaic (1800 B.C.-A.D. 900)	4	5	9	4.6
Unknown/Unspecified Archaic	1	1	2	1.0
TOTAL	6	9	15	7.7
ANASAZI (A.D. 1-1600)				
BM II (A.D. 1-500)		1	1	.5
BM II/P I (A.D. 1-900)	1		1	.5
BM III/PI (A.D. 500-900)	1		1	.5
P I/P II (A.D. 700-1100)	3		3	1.5
P II/P III (A.D. 900-1300)	3		3	1.5
PII/PIV (A.D. 900-1600)		1	1	.5
P III (A.D. 1100-1300)	15	9	24	12.3
P III/P IV (A.D. 1100-1600)	16	4	20	10.3
P IV (A.D. 1300-1600)	15	2	17	8.7
Unknown/Unspecified Anasazi	4	2	6	3.1
TOTAL	58	19	77	39.5
PLAINS				
Panhandle Aspect (A.D. 1000-1600)	1		1	.5
HISTORIC				
PUEBLO				
Spanish Contact/Mexican/Santa Fe Trail (A.D. 1539-1846)	2	2	4	2.1
Post Pueblo Revolt (A.D. 1692-1821)	1	1	2	1.0
TOTAL	3	3	6	3.1
APACHE				
Spanish Contact/Colonial (A.D.1539-1680)		2	2	1.0
Unspecified Historic (A.D. 1539-1880)		1	1	.5
TOTAL		3	3	1.5
HISPANIC				
Spanish Contact/Colonial (A.D.1539-1680)		1	1	.5
U.S. Territorial (A.D. 1846-1912)		1	1	.5
U.S. Territorial/WW II (A.D. 1846-1945)	2	5	7	3.6
TOTAL	2	7	9	4.6
ANGLO				
Post Revolt/U.S. Territorial (A.D. 1821-1912)		2	2	1.0
U.S. Territorial (A.D. 1846-1912)	1	6	7	3.6
U.S. Territorial/WW II (A.D. 1846-1945)	8	10	18	9.2
Statehood/WW II (A.D. 1912-1945)	5	5	10	5.1
Recent (A.D. 1945-DATE)	4	3	7	3.6
TOTAL	18	26	44	22.6
UNKNOWN				
Unspecified Prehistoric (9500B.C.-A.D. 1539)	1	1	2	1.0
Unspecified Historic (A.D. 1539-DATE)	1	3	4	2.1
Unknown (9500 B.C.-Date)	18	16	34	17.4
TOTAL	20	20	40	20.5
GRAND TOTAL	108	87	195	100.0

Table 2. Anasazi Site Types and Features

SITE TYPE AND FEATURES	SETON VILLAGE QUAD	GLORIETA QUAD	TOTAL
Residential Complex/Community	3		3
Multiple Residence			
Room Block	3		3
Mound/Depression	1		1
Pit House	1		1
Single Residence			
Isolated Room	3		3
Simple Features			
Shrine/Rock Alignment	2		2
Garden Plot	1		1
Features and Artifact Scatter			
Room Block/Mound	1	1	2
Stone Circle	1		1
Garden Plot	2		2
Shrine	2		2
Indet. Rock Alignment	4	2	6
Hearth/ Fire-cracked Rock	3	1	4
Artifact Scatter	9	10	19
Unknown			
Room Block	1	3	4
Room Block/Depression	3		3
Depression/Pit House	3		3
Mound	1		1
Hearth	1		1
Shrine	2		2
Indeterminate	11	2	13
TOTAL	58	19	77

of secondary manufacturing flakes of local cherts, chalcedonies, and both Jemez and Polvadera obsidian. An Archaic period Armijo phase (1800-800 B.C.) lithic scatter consisted of 13 recorded pieces of lithic manufacturing debris diffusely scattered in a 25-by-40 m area. Of interest was a small mound interpreted as the remains of an adobe fieldhouse. The mound measured 10 m in diameter and .75 m high. At least 30 artifacts were observed in a 15-by-25-m area. The ceramic assemblage was dominated by Galisteo Black-on-white sherds along with Wiyo(?) Black-on-white and indented corrugated gray wares. Four pieces of chipped stone included local chert, quartzite, and Jemez obsidian. An Archaic period Armijo-style projectile point manufactured from Jemez obsidian was also found on the site. The ceramics suggest that the late Coalition-early Classic period fieldhouse is contemporaneous with LA 115266.

The single Coalition period fieldhouse illustrates how low Anasazi site density is in the 424-acre subdivision. The 32 isolated occurrences were located along the ridge containing the sites, but with the exception of a single gray ware sherd, use of the lithic materials can not be temporally differentiated. The fieldhouse is immediately adjacent to the base of the foothills about 3 km southeast of both LA 115266 and the Cañada de los Alamos. The fieldhouse appears situated to take advantage of farming along a small tributary drainage originating from the foothills rather than the Cañada de los Alamos terraces.

The Los Caballos Estates subdivision included survey of a 253-acre tract along the east terrace of the Cañada de los Alamos arroyo immediately south of LA 115266 (Marshall 1993). The survey recorded 3 Coalition period sites and 12 cultural localities. Five of the localities were prehistoric manifestations consisting of indeterminate isolated sherds (n = 3), one obsidian flake, and one side-notched obsidian projectile point. The prehistoric component of LA 100777 is a pot drop represented by 10 sherds from a single corrugated-indented jar. The jar was assigned a general P III-P IV

temporal affinity. The other two sites introduce residential pithouse occupations into the local Anasazi settlement pattern. LA 100778 is located 1 km south of the project and is described as a pithouse complex of one to three depressions and an associated midden area. A jacal unit house might be present and one extramural hearth was noted. Artifacts estimated at 1,000 items were scattered in a 40-by-40-m area. The ceramic assemblage consisted of Red Mesa Black-on-white (n = 1), Kwahe'e Black-on-white (n = 1), Santa Fe Black-on-white (n = 15), unidentified white ware (n = 10), plain gray (n = 25), and corrugated-indentured (n = 28). The ceramics suggest an occupation from about A.D. 1150 to 1200 during the early Coalition period (Marshall 1993:10). Observed chipped stone artifacts were manufactured from chalcedony, gray chert, basalt, quartz, and obsidian.

LA 100779 is another pithouse hamlet located along the eastern edge of the Cañada de los Alamos and 500 m south of LA 100778. One pithouse depression was recorded and an estimated 100 to 200 ceramics and 10 lithics extended over a 25-by-30-m area. Observed ceramic types included Santa Fe Black-on-white (n = 12), unidentified white ware (n = 1), plain gray-brown (n = 7), corrugated-indentured (n = 30), and Los Lunas Smudged (n = 1). The utility ware materials were brown to gray in color with a micaceous-granitic sand temper. The ceramics suggest a Coalition period occupation.

Marshall (1998:16-18) recorded another possible pithouse habitation site in the same general area during survey along U.S. 285. LA 115268 is less than .5 km south of LA 115266. The site is recorded as an artifact scatter associated with one or two pit structures. The Coalition period temporal affinity is defined by plain gray utility sherds (n = 15), corrugated-indentured sherds (n = 15), one neckbanded sherd, and one Santa Fe Black-on-white sherd. Test excavations verified that the site is preserved mainly west of the right-of-way fence and the 189 recovered sherds substantiate an extended residential occupation contemporaneous with Pueblo Alamo (Post 1999:18-24).

The Dos Griegos subdivision was a 435-acre survey of piedmont slope, isolated foothill landforms, and Cañada de los Alamos terraces immediately north of the project area (Viklund and Scheick 1989b). The survey recorded 15 sites and 89 isolated occurrences. Most of the isolated occurrences are chipped stone artifacts consisting mainly of secondary flakes of chert, chalcedony, basalt, and both Jemez and Polvadera obsidian. The remaining seven isolated occurrences are ceramics dating from the Coalition-Classic periods. Recorded sites span a period of time beginning with the Late Archaic and continuing into the Classic period. Temporal affinity of the chipped stone isolated occurrences scattered across the landscape, therefore, is considered mixed. All of the sites, except LA 75691, are interpreted as limited activity loci associated with hunting and wild plant collecting, expedient and formal tool manufacturing and maintenance activities, and agricultural use (Viklund and Scheick 1989b:36). LA 75691 is considered a specialized hilltop shrine associated with the nearby sites of Pueblo Alamo and Chamisa Locita.

The two large villages of Pueblo Alamo (LA 8) and Chamisa Locita (LA 4) are just north of the Dos Griegos survey area. The survey indicates that Anasazi site density and land use increased in proximity to these large sites. Twelve sites had Anasazi components with mainly Coalition-Classic period affiliations. Site types included four fieldhouse structures and eight artifact scatters. Rubble mounds indicate masonry rather than adobe fieldhouses. Three fieldhouses are situated along the western edge of the Cañada de los Alamos. The structures are spaced about every .5 km along the arroyo with the first site located about .5 km north of LA 115266. The fourth fieldhouse is situated on the south edge of the Gallina Arroyo and just south of Chamisa Locita. This fieldhouse is apparently situated to farm along the Gallina Arroyo rather than the Cañada de los Alamos.

Rubble mounds averaging 5 m in diameter and standing about 1 m tall characterize the four fieldhouses. The structures are thought to consist of an average of two rooms. The sites have very sparse surface artifact assemblages ranging from 2 to 15 artifacts. Artifacts at two sites are each

limited to only two pieces of chipped stone represented by chert, chalcedony, and Polvadera obsidian secondary flakes. A third site was limited to six secondary flakes of Jemez obsidian, chert, and basalt, and one gray ware sherd. The largest assemblage consisted of 15 flakes of chalcedony and Jemez obsidian.

Lang (1992:15-53) discovered an additional poorly preserved jacal fieldhouse during excavations at one of the Dos Griegos artifact scatters. The fieldhouse is about 1.5 km north of LA 115266 and .5 km south of the large village sites of Pueblo Alamo and Chamisa Locita. This is one of the few excavated sites in the project area. The multicomponent site evidences periodic occupation extending from the Archaic-Basketmaker II to the Coalition period. The Coalition period jacal fieldhouse component centered on farming activities. Its use over an extended period of time is indicated by four probable floor remodelings and a ceramic assemblage of 750 pottery sherds representing an estimated 391 vessels (Lang 1992:39, 103-104). Other activities included hunting, the manufacture of ground and chipped stone tools, hide working, and food processing. Of interest was the recovery of clay, incompletely fired vessel fragments, and a probable pottery scraper, suggesting pottery manufacture was another site activity. The site should be regarded as a measure against which to assess the other Anasazi "artifact scatters" in the project area. The site was visible on the surface as an artifact scatter consisting of only about 50 artifacts.

LA 4 and LA 8 are located just over 2 km north of LA 115266. The various Pueblo period components just described are within the sustaining area of these large villages (Viklund and Scheick 1989b). Pueblo Alamo (LA 8) was formerly located at the intersection of U.S. 285 and I-25. The coursed adobe pueblo consisted of four to five single-story roomblocks with a linear layout measuring 550 ft east-west by 100 ft north-south. Excavations at Pueblo Alamo began with the work of Nels Nelson in 1915. Nelson excavated 25 to 30 rooms in the estimated 80- to 100-room pueblo (Nelson 1915). In 1971, the Museum of New Mexico conducted salvage excavations at the site for the construction of the I-25 interchange (Allen 1973). The interchange removed all but the extreme eastern and western tips of the pueblo. Some 60 rooms were salvaged during the project including a subsurface pit room, three conventional kivas, and three or four conventional rooms remodeled into special-purpose "room kivas" (Allen 1973:7).

Architecture indicates that Pueblo Alamo had three broad periods of occupation. Distinct occupations are evidenced by the presence of at least one small Coalition period pithouse situated beneath later surface rooms, a major pueblo complex largely destroyed by widespread fire, and subsequent reconstruction of the pueblo complex. In addition to these broad level occupations, various floor remodelings and wall abutments evidence a complex occupation extending over a fairly long period of time. Tree-ring samples have yielded a series of dates starting with A.D. 1061vv and ending with A.D. 1284vv (Robinson et al. 1973). Actual cutting dates include samples at A.D. 1244 and A.D. 1256, and multiple samples at A.D. 1261 (n = 5), A.D. 1262 (n = 4), and A.D. 1263 (n = 7) (Wiseman 1999:233). Santa Fe Black-on-white was the primary pottery type followed by smaller amounts of Galisteo Black-on-white.

Pueblo Alamo apparently grew by general accretion with little concern for defense. The site affords easy access from all directions, and there was apparently no concern for grouping rooms around plazas (Allen 1973:11). However, the pueblo was almost completely consumed by fire sometime during the middle of the occupation. The widespread nature of the fire suggests enemy action (Allen 1973:11). The date of the fire was not determined, and the pueblo may have been briefly abandoned after the event. A 40-cm-thick layer of fire-burned rubble was encountered in the trash, apparently originating from the upper sections of walls that were razed and rebuilt after the fire. New walls were often laid directly over earlier fire-damaged walls. Sections of the original adobe walls fire-hardened by the intense fire were set in mortar and utilized as "building bricks" during the reconstruction. Final abandonment was gradual and occurred sometime around A.D. 1300 (Allen

1973:14).

Chamisa Locita, or Pueblo Wells (LA 4), is located about 1 km west of Pueblo Alamo. The 250-300 room adobe pueblo sits in a basin formed by the confluence of several minor arroyos. The site is situated on the Gallina Arroyo rather than the Cañada de los Alamos. Canyon Ancho forms a gap in the foothills at this locality, and the Gallina Arroyo drains eastward across the piedmont slope. Chamisa Locita consists of a long east-west mound with four perpendicular mounds extending to the south. Four additional mounds are clustered south of the main E-shaped pueblo. A circular depression represents a probable kiva. The multistoried pueblo covers a 350 ft north-south by 450 ft east-west area. The site can be easily approached from all directions and does not seem to be defensively situated. However, several nearly enclosed plazas are represented contrasting with the linear layout of Pueblo Alamo. Nelson (1915) excavated 44 rooms including a room with walls decorated with red painted lines and thin zigzag motifs. The Santa Fe Archaeological Society (1959) dug three additional rooms. Outside of these poorly documented projects, no recent excavations have been conducted at this important Coalition period pueblo. Five tree-ring dates span the A.D. 1313 to 1333 period (Smiley et al. 1953:15). Ceramics from the site include Santa Fe Black-on-white, Galisteo Black-on-white, Pindi Black-on-white, Poge Black-on-white, and Rio Grande Glaze I Red. The ceramics suggest an occupation between A.D. 1200 and 1400+ (Dickson 1979:118). However, the clustering of tree-ring dates between A.D. 1313 and 1333 may indicate a shorter occupation span ending before A.D. 1350. Chamisa Locita and Pueblo Alamo are contemporary Coalition period village complexes, but Pueblo Alamo was apparently abandoned before Chamisa Locita.

In addition to the residential complexes, a hilltop shrine is located on the crest of a nearby isolated foothill (Hannaford 1998). The shrine is located east of Chamisa Locita and south of Pueblo Alamo. The shrine consists of a circular ring of piled granite 11.5 m in diameter and averaging about .5 m in height. The hilltop commands a panoramic view of the surrounding region as well as both pueblos. The structure is similar to Pueblo “earth-navel” shrines found throughout the upper Rio Grande Valley. A similar hilltop shrine overlooks Arroyo Hondo (Ware 1991:15-16). The hilltop shrine was undoubtedly an important ritual or ceremonial aspect of the local prehistoric Pueblo landscape.

Pueblo Alamo and Chamisa Locita were occupied somewhat earlier than, and contemporaneously with Arroyo Hondo Pueblo (LA 12) and the nearby site of upper Arroyo Hondo (LA 76). By A.D. 1330, as the populations of Pueblo Alamo and Chamisa Locita were declining, Arroyo Hondo, located 5 miles to the northwest, had expanded into a 1,000+ room village including 24 roomblocks, 10 plazas, and covering a 6-acre area. The site was nearly abandoned during the middle of the fourteenth century. A new village consisting of nine roomblocks and three plazas was rebuilt and flourished until final abandonment around A.D. 1425. During the population peak, the 1,000 to 2,000 occupants of Arroyo Hondo dominated the area north of the project. Dickson’s (1979:32-33) survey of the Arroyo Hondo Pueblo area recorded 29 early, 29 middle, and 24 late phase Coalition period sites. Site types included limited activity artifact scatters, pithouse sites, and pueblos of between 2 and 1,000 rooms.

The Galisteo Basin south of the project area saw a similar pattern of population growth and community aggregation. Important Coalition period sites include Manzanares (LA 1104), Piedra Lumbre Pueblo (LA 309), Lamy (LA 10), and the oldest sections of Pueblo Largo (LA 183). The Galisteo Basin became a major population center during the Classic period with the formation of a number of large pueblos between A.D. 1350 and 1475. Several of these pueblos, including San Cristobal, Galisteo Pueblo, and San Lazaro, remained important centers of Pueblo activity into historic times.

EXCAVATION RESULTS

LA 115266 was originally recorded as a hearth area and artifact scatter with an Anasazi Pueblo II-III cultural affinity (Marshall 1998:12-14). The hearth was characterized by charcoal-stained soil and fire-cracked rock. A diffuse scatter of artifacts, including five pieces of chipped stone and three sherds, was distributed over a 22-m-diameter area. LA 115266 sits on a low rise formed by the confluence of a small side drainage from the east with the Cañada de los Alamos. The site is actually situated on the eastern terrace of a small, unnamed 20-m-wide drainage paralleling the main channel of the Cañada de los Alamos. The current floodplain of the Cañada de los Alamos is about 40 m west of the site. The open grass-covered rise is surrounded by stands of piñon and juniper (Fig. 2). Site elevation is 2,134 m (7,000 ft).

Test excavations revealed a more complex site than indicated by the survey (Post 1999:11-18). The primary site element visible from the surface was the hearth, which was truncated by the right-of-way fence and a subsurface utility line. The remaining 130-by-85-cm oval-shaped segment was eroded and deflated. A 30-by-50-cm test pit revealed an 8-cm deposit of mixed and deflated sandy loam. The fill was lightly stained, but no charcoal was recovered. The fill contained 27 fire-cracked metamorphic cobbles suggesting a cooking or roasting facility. No artifacts were found in the fill, though an obsidian flake was recovered from the edge of the feature. The hearth was separated from the main site area on the rise by about 10 m. No surface artifacts were observed in the area between the hearth and the main site area. The spatial separation suggested a discrete site component, but the absence of diagnostic artifacts prevented assignment of a specific temporal affiliation. The hearth is considered an unknown prehistoric component related to a short-term hunting or foraging excursion. The remaining portion of the deflated hearth had limited integrity and no data potential. No further investigations were proposed for this component of the site (Post 1999:27).



Figure 2. Overview of main site area; plastic marks the location of Pit Structure 1.

Testing discovered a burned structure on the terrace top that was not recognized during the original site recording. The structure was not visible on the surface and surrounding cultural material was limited to a diffuse artifact scatter consisting of only two sherds and seven chipped stone artifacts. This Coalition period fieldhouse associated with agricultural activities along the Cañada de los Alamos represents the primary site component. The excavation program focused on defining the prehistoric structure and surrounding extramural features associated with the occupation.

During excavation, a stone-lined hearth was discovered. The hearth had been constructed over the prehistoric fieldhouse and represents the latest site component. A single burned peach pit suggests an unknown historic affiliation dating sometime between the founding of the Cañada de los Alamos land grant in 1785 and World War II. The hearth probably represents a short-term camp associated with sheep and cattle ranching, which was the primary economic activity during this time. In summary, LA 115266 is a multicomponent site characterized by an unknown prehistoric hearth component, the primary Coalition period fieldhouse component, and an unknown historic hearth component.

Condition

Several natural and mechanical processes have transformed the interpretive integrity of the site. The original construction of U.S. 285 would have removed any cultural materials extending east of the structure. North-extending site elements may have been lost by erosion associated with an arroyo along the northern site boundary. The arroyo drains the nearby eastern foothills and is currently inactive because of drainage modification associated with U.S. 285. In general, the main site area is stable and intact. The site slopes gently to the south and cultural material has not been subjected to extensive erosional mixing. In contrast, the unknown prehistoric hearth on the steeper western terrace slope has lost most of its interpretive value to erosion.

At least one juniper tree has been recently burned on the site. The age of the burn is unknown, but the event probably occurred sometime within the last one hundred years. The incident has introduced a major source of “tainted” charcoal onto the site. Rodent burrows were commonly encountered during excavation and rodent activity has undoubtedly mixed the recently introduced charcoal throughout the shallow cultural deposits. In addition to this recent source of charcoal contamination, the excavation program uncovered a historic period hearth built directly over the prehistoric structure. Rodent action has introduced charcoal from the hearth into the prehistoric structure fill. The problem of mixed and contaminated charcoal greatly limits the chronometric potential of the cultural deposits.

Field Methods

The excavation program followed field methods outlined in the data recovery plan (Post 1999:35-36). All excavation was by hand, using standard archaeological hand tools. All fill was screened, with the mesh size determined by the excavation context. Surface strip and cultural layer fill was screened through ¼-inch mesh. Pit structure fill and feature fill was screened through ⅛-inch mesh.

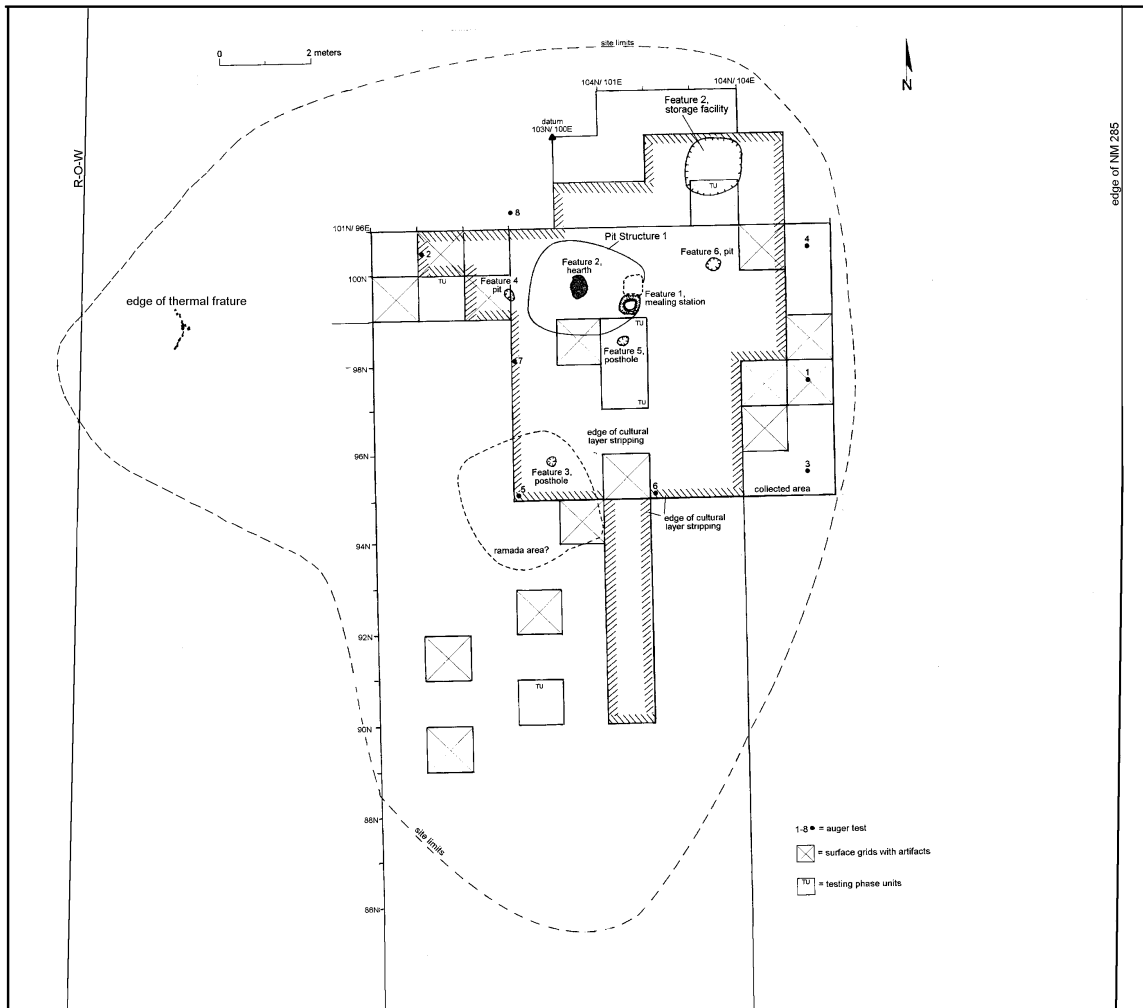

Figure 3. LA 115266, site map.

Surface Collection

Archaeological investigations began with the collection of surface artifacts. Systematic surface collection was carried out by establishing a 1-by-1-m grid system over the site (Fig. 3). The grid system was projected from the site datum and grid stakes left behind by the testing phase. The grids are aligned with magnetic north and provenienced from the southwest corner. The site datum was moved to 103N/100E at the north end of the site and marked with rebar. The ground surface at this point was designated an arbitrary 0 meter elevation.

The grid system covered a 19-by-10-m area surrounding the structure found during the testing program. The testing program established that the main site area was restricted to a 5-by-5-m (25-sq-m) area around the structure (Post 1999:13). The surface of 153 individual grids was intensively inspected. Surface visibility was excellent with the exception of a yucca and chamisa patch along the east edge and thick junipers along the north boundary (Fig. 3). The area outside of the grid system was additionally inspected by archaeologists walking shoulder-to-shoulder transects. No surface artifacts were encountered outside of the grid system.

The surface assemblage is comprised of only 17 artifacts including 12 sherds and 5 pieces of chipped stone. The 12 sherds are all smaller than the size of a dime. The small sherd sizes are most likely the consequence of long-term regional sheep and cattle trampling. Gray ware (n = 10) is the most common type followed by two painted white ware sherds. Chipped stone artifacts are represented by chalcedony (n = 3), obsidian (n = 1), and quartzite (n = 1) core reduction flakes.

The surface investigation identified a dispersed low-density artifact scatter. The artifacts were recovered from 14 grids; only 2 grids contained two artifacts. Over 90 percent (n = 139) of the grids were empty. The majority of the artifacts (n = 12) were located in the northern 6 m of the site. These artifacts were diffusely scattered east (n = 6) and west (n = 5) of the structure and main site elements, but none of the cultural features were visible from the surface. Only one sherd marked the actual location of the structure. The remaining five artifacts were scattered south and downslope of the main site area.

The surface examination revealed no evidence of midden areas or other cultural features. The surface soil was lightly charcoal-stained, but the staining could be attributed to the recent tree burn in addition to cultural activity. No oxidized or fire-cracked rock was evident on the surface. In summary, surface manifestations characterized a diffuse artifact scatter with no evidence of the buried structure and six extramural features.

Stratigraphy

Site testing defined a shallow cultural deposit with a depth of only about 10 cm (Post 1999:13). The excavation program confirmed this observation (Fig. 4). The cultural deposit is characterized by a shallow layer of brown sandy loam extending from the surface to an average depth of 10 cm and a maximum depth of 20 cm below the surface. The cultural layer is infused with light cultural staining and charcoal flecks. Artifact content is low. The prehistoric ground surface, or occupation surface, could not be determined. No obvious breaks in the homogeneous cultural layer were apparent.

The shallow cultural layer was followed by a massive layer of natural alluvium consisting of orange sandy clay. Eight systematically placed auger tests showed that this natural layer extended to a depth of at least 1 m below the modern ground surface. Auger tests revealed a series of alluvial layers ranging from coarse sand and pea gravel to thick clay. No cultural deposits or artifacts were encountered in the alluvial layer, which is considered sterile. The darker cultural layer contrasted nicely with the natural orange alluvium and the outline of the cultural features dug into the alluvium were readily apparent. The cultural deposit was divided into two arbitrary excavation units: surface strip and cultural layer.

Surface Strip

Subsurface investigations began with the surface stripping of a 6-by-7-m area around the probable structure. There were no surface indications of site elements and the intent of this procedure was to define the outline of the structure and locate associated extramural features. The surface strip consists of half of the cultural deposit. An average of 5 cm of surface soil and grass was removed from 46 grids. This procedure resulted in the discovery of one extramural feature and the recovery of 73 artifacts including 67 sherds, 5 pieces of chipped stone, and 1 piece of animal bone (Table 3). However, surface stripping failed to define the majority of the excavated features. Artifacts were recovered from 31 of the 46 surface-stripped grids, but artifact density was low. Grids with artifacts

ranged in frequency from 1 to a maximum of 12 artifacts. Artifact frequencies provided little evidence on feature location. Only two small sherds were recovered from the grids overlying the structure. The majority of the artifacts appeared as light refuse in grids north (n = 25) and east (n = 27) of the structure.

Cultural Layer

The cultural layer is an arbitrarily assigned designation referring to the lower half of the occupational deposit. The remaining 5 to 10 cm of culturally stained brown sandy loam between the surface strip and the sterile alluvial substratum was removed from 46 grids. Frequently encountered rodent burrows indicate profuse mixing of the surface strip and cultural layer. The removal of the cultural layer aided in the discovery and definition of the structure and five additional extramural features. As the cultural layer was removed, dark feature fill contrasted with the surrounding orange natural alluvium and features were easily exposed and delineated. The prehistoric surface is most likely located within the cultural layer, but an actual activity surface was not identified. The pit structure and extramural features were invisible within the layer. Any surficial and ephemeral features not dug into the lower sterile alluvium were imperceptible.

Fifty-three artifacts were recovered from the cultural layer including 30 sherds, 7 lithics, 15 faunal fragments, and 1 mano. Artifact frequency decreased compared with the surface strip, and artifacts were found in less than half (n = 20) of the 46 investigated grids. Artifact density was low. Grids with artifacts ranged in frequency from 1 to 7 artifacts. The higher counts were from faunal fragments collected from three grids west of the structure, but several fragments were the result of excavation breakage (see Table 5). Artifacts were equally distributed in grids mainly east and west of the structure. Only five artifacts were recovered from the five grids sampling the southern site area (Fig. 3). Nine artifacts including five sherds, three pieces of chipped stone, and a mano fragment were collected from five grids around the structure.

Table 3. Artifact Frequency by Grid and Level

GRID	Provenience			Total
	Surface	Surface Strip	Cultural Layer	
99N/96E	2			2
100N/97E	2		5	7
91N/97E	1			1
89N/97E	1			1
100N/98E		1	7	8
99N/98E	1		6	7
100N/99E			1	1
99N/99E			1	1
97N/99E		1		1
96N/99E		3	4	7
92N/99E	1			1
102N/100E		5		5
100N/100E		6	5	11
98N/100E	1			1
97N/100E		2		2
96N/100E		2		2
95N/100E		1		1
94N/100E	1			1
102N/101E		2		2
101N/101E		1		1
100N/101E			1	1
99N/101E		2		2
98N/101E			1	1

96N/101E		1		1
95N/101E	1			1
94N/101E			2	2
91N/101E			2	2
90N/101E			1	1
103N/102E		2		2
102N/102E		12		12
101N/102E		2		2
100N/102E		2	1	3
95N/102E		2	2	4
102N/103E		1	1	2
100N/103E		5		5
99N/103E		3	2	5
98N/103E		1	3	4
97N/103E		3		3
96N/103E			2	2
95N/103E		1		1
101N/104E			2	2
100N/104E	1	2	4	7
99N/104E		4		4
98N/104E		2		2
97N/104E	2	3		5
96N/104E	1			1
95N/104E		1		1
98N/105E	1			1
97N/105E	1			1
TOTAL	17	73	53	143

Cultural Features

Data recovery focused on the probable jacal structure and adjacent activity area. Excavation revealed a pit structure and six extramural features. The pit structure, five extramural features consisting of various pits, and the recovered artifact assemblage are considered contemporary and related to the primary Coalition period component. A stone-ringed hearth and a peach pit are associated with an unknown historic component.

Surface artifacts were found scattered over a maximum 12-by-10-m area. Just over 40 percent of this area was investigated by 1-by-1-m units excavated to sterile soil. These 1-by-1-m exploratory units were excavated around the perimeter of the pit structure and as many units as possible were excavated over the course of the allotted two-week field phase. Shallow cultural fill may extend another 3 to 5 m north of the pit structure. Excavation in this area was impeded by a dense growth of juniper. A possible ramada posthole was discovered at the south end of the site, but no matching postholes were found within the excavated area. A description of the features follows.

Pit Structure 1

Pit Structure 1 was not discernible from the surface and was not recorded as a site element during the original survey (Marshall 1998). The structure was originally discovered by Post (1999:11) during the testing program. Test Unit 98N/101E examined an area of charcoal-infused soil and the south edge of the structure was exposed. However, the structure encountered during the testing program was not a shallow jacal surface structure as initially thought, but instead was a pit structure. Initially, the area was surface stripped, but this procedure failed to delineate the structure. The pit structure was discovered when the cultural layer was removed. The darker pithouse fill contrasted with the

surrounding natural alluvium and the outline was discernible. The pit structure was defined within a 3-by-3-m area with grid stake 98N/99E as the southwest corner (Fig. 3). The outline of the pit structure was fully exposed at a depth of 10 cm below the modern surface.

Shape and Size. Pit Structure 1 was a rectangular structure with well-rounded corners (Fig. 4). The structure measured 2.3 m east-west by 2.0 m north-south. The structure had been dug 45 cm into the natural alluvium. The floor averaged 55 cm below the modern ground surface. The longer east-west axis suggests that the structure was oriented toward the south, but there was no evidence of an actual entryway. I assume entry was through the roof.

Walls. The walls of the basin-shaped structure slanted gently inward with only a slight curve at floor contact (Fig. 4). The walls were poorly preserved and disturbed by rodent activity. Large rodent dens cut through both the north and south walls. An occasional small fragment of white plaster from the fill suggests that the walls were originally plastered and whitewashed.

Structure Fill. The pit structure fill was divided into three excavation units (Fig. 4).

General fill was the initial 30-cm-thick layer of brown sandy loam indistinguishable from the general occupational fill encountered across the site. The layer had only rare charcoal flecks. The 63 recovered artifacts included 55 sherds, 5 pieces of chipped stone, 2 faunal fragments, and 1 mano fragment. Twenty burned granite cobbles measuring less than 10-by-10 cm were scattered throughout the layer.

Roof fill was a 15-cm-thick layer between the general fill and floor contact. The layer was similar in appearance to the general fill, but contained adobe roof melt and small oxidized adobe fragments. No actual wood or other closing material from the roof was encountered, but some adobe fragments contained impressions of organic roofing material. An occasional small fragment of whitewashed plaster was found from the deteriorated walls. Artifact frequency decreased to 17 sherds and 1 piece of chipped-stone. Ten burned granite cobbles measuring smaller than 10-by-10 cm were noted mainly from the northeast corner of the structure.

Floor fill was an arbitrary 3- to 5-cm-thick division of the lower portion of the roof fill resting on the poorly preserved floor. No artifacts were recovered from the floor fill.

Floor. The floor was poorly preserved, and, like the walls, was disturbed by numerous rodent holes that complicated floor definition. The unprepared floor consisted of the leveled and smoothed bottom of the original pit. The surface of the natural alluvium was compacted and darkened from use. Artifacts were limited to a single complete metate (Fig. 4). The slab metate, originally associated with a mealing station built against the east wall, had been removed and abandoned next to the north wall.

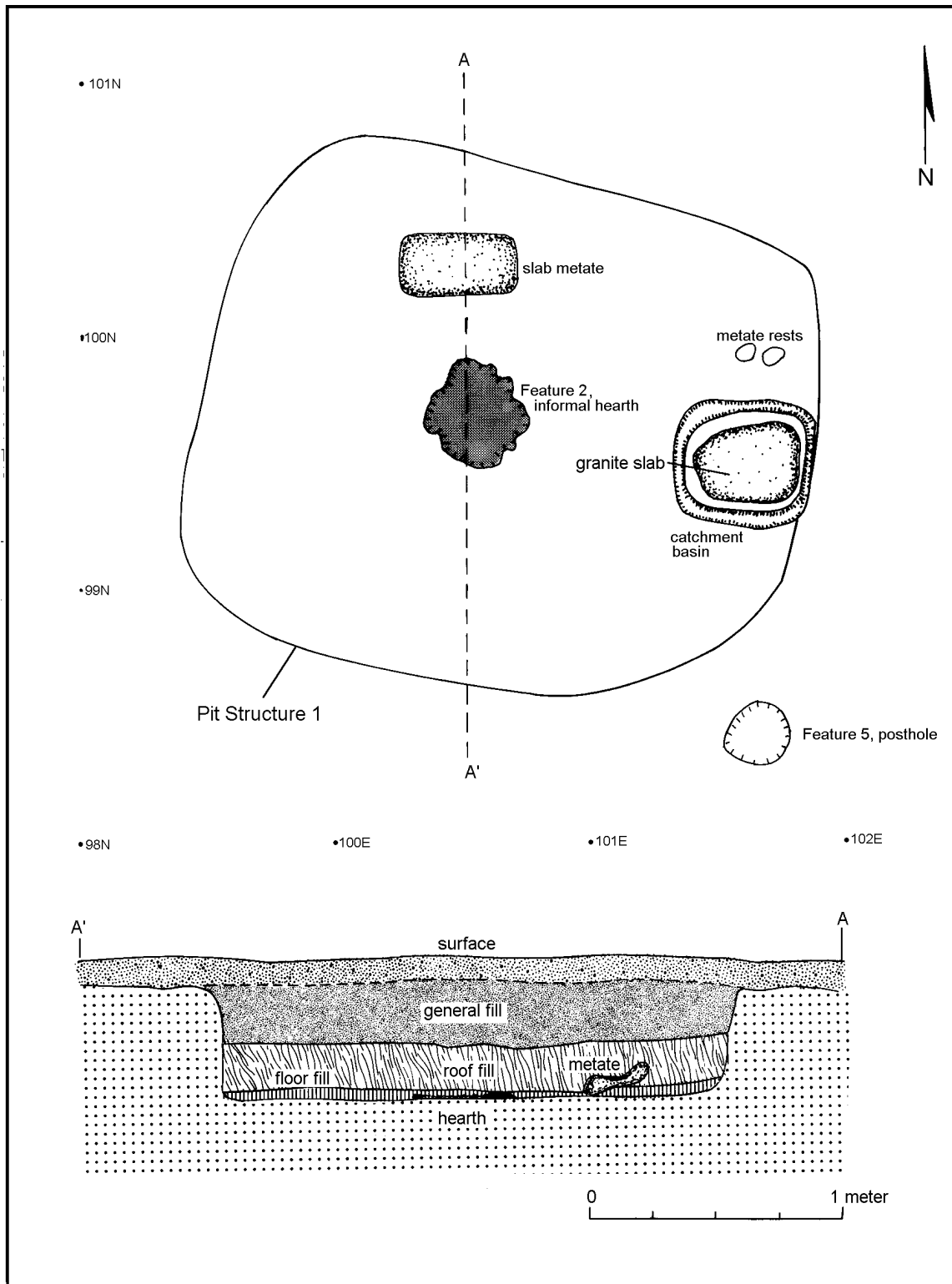

Figure 4. Pit Structure 1, plan and profile.

Floor Features. Floor features were limited to a mealing station built against the east wall and a central informal hearth.

Mealing Station (Feature 1). A mealing station was built against the east wall of the pit structure (Fig. 4). The catchment basin consisted of a tabular, unmodified granite slab set horizontally into the floor and surrounded by a 5-cm-thick adobe collar (Fig. 5). The granite slab measured 34-by-25-by-5-cm thick and was set even with the floor level. The surrounding adobe collar formed a circular basin measuring 37-by-39 cm and rising about 3 cm above the slab. The granite slab was set into the adobe and could not be removed during use. Two granite cobbles measuring 5-by-5 cm were set side by side in the floor 10 cm north of the catchment basin. The stones protruded about 3 cm above the floor and apparently served as metate rests or braces. The metate area was not surrounded by a bin or adobe enclosure. The space between the catchment basin and the south wall is about 50 cm. This provided just enough room for an individual to brace their feet against the south wall during the mealing process. The slab metate had been removed and abandoned near the north wall.

Informal Hearth (Feature 2). An informal hearth, or floor burn, was situated in the center of the structure (Fig. 4). The irregular burn was located directly on the floor, but was not contained in a pit, or surrounded by an adobe or slab enclosure. The pit structure did not have a ventilator. The irregular burn measured about 40-by-40 cm and contained about 2 cm of fill. The fill consisted of small charcoal fragments and charcoal-stained soil. No artifacts or fire-cracked rocks were recovered. The floor was slightly oxidized by the low-intensity burn, but the quality of the burn was inadequate for an archeomagnetic sample. The informal hearth exhibits characteristics of a single burning episode. The small fire is interpreted as an unplanned spur-of-the-moment event, such as the need for warmth on a cold day during the spring planting or fall harvest. A laboratory scan showed that sage was the fuel-wood burned in the informal hearth. The charcoal was not submitted as a radiocarbon sample at this time because of the “old wood effect” associated with sage, compounded by the general problem of contaminated charcoal on the site.

Roof. With the exception of occasional pieces of burned adobe, no direct evidence of the roof or its construction details was found. A few adobe peds contained shrub-sized twig impressions, but no larger beam impressions were noted. No internal postholes were found, and it is unclear whether two nearby extramural postholes were related to roof construction. Entry was probably by ladder through a roof hatch, but no landing area or ladder holes were identified on the floor.

Summary. The pit structure (rather than a jacal surface structure as originally defined) was an unexpected discovery (Fig. 6). The structure most likely functioned as a seasonally occupied farming shelter. The absence of a formal hearth and ventilation system suggests that occupation was not year-round. However, the prehistoric excavation of the structure represented a rather substantial labor investment. The natural alluvium is compact and digging is hard even with metal tools. The simple layout indicates a short-term occupation ending with a leisurely abandonment. The structure was lightly burned, as evidenced by the occasional small oxidized adobe fragments from the roof. The walls and floor were not oxidized, and charcoal was generally sparse in the fill. The low to moderate artifact frequency in the fill may be attributed to the general dispersion of the shallow occupational sheet-trash by post-abandonment processes, and possibly the low level continuation of activities after structure abandonment, resulting in the light trash-filling of the structure.

Extramural Features

Six extramural features were found during the excavation program. None of the features was visible from the surface. A stone-ringed hearth associated with a later unknown historic component was built directly over the southwest corner of the pit structure. The remaining five features were associated with the pit structure and the primary Coalition period occupation.

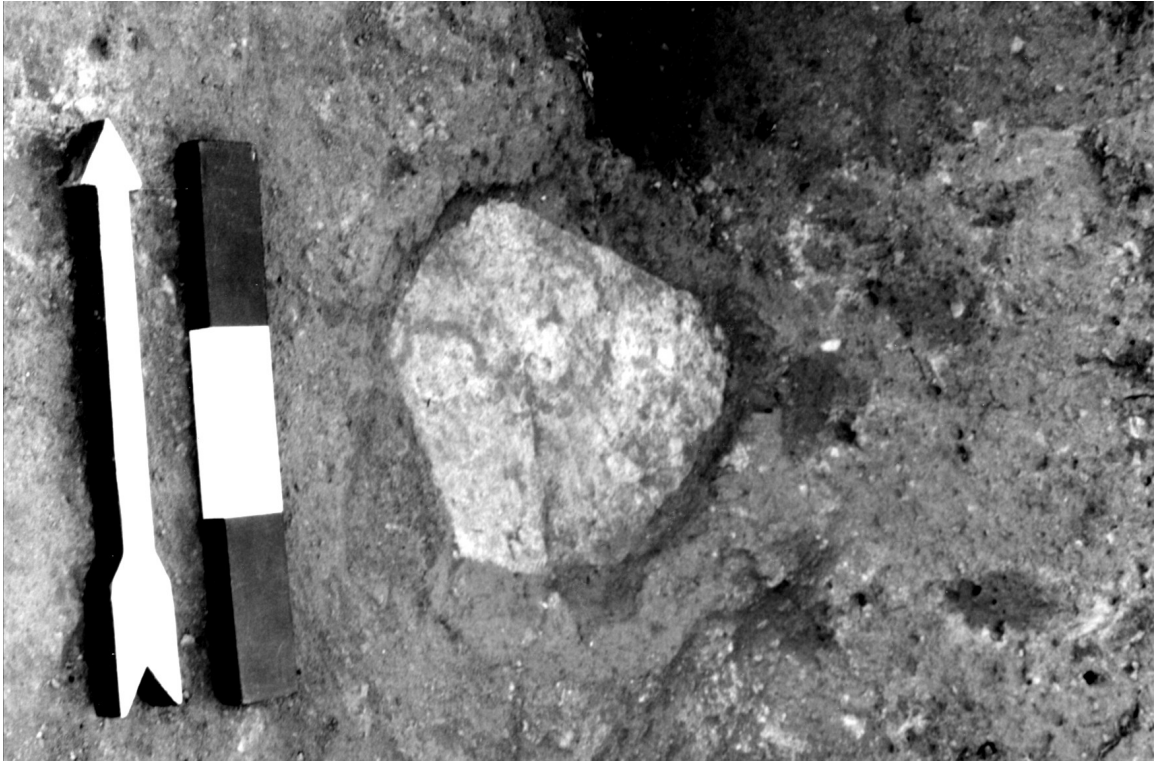

Figure 5. Pit Structure 1, mealing station (Feature 2), detail of catchment basin.

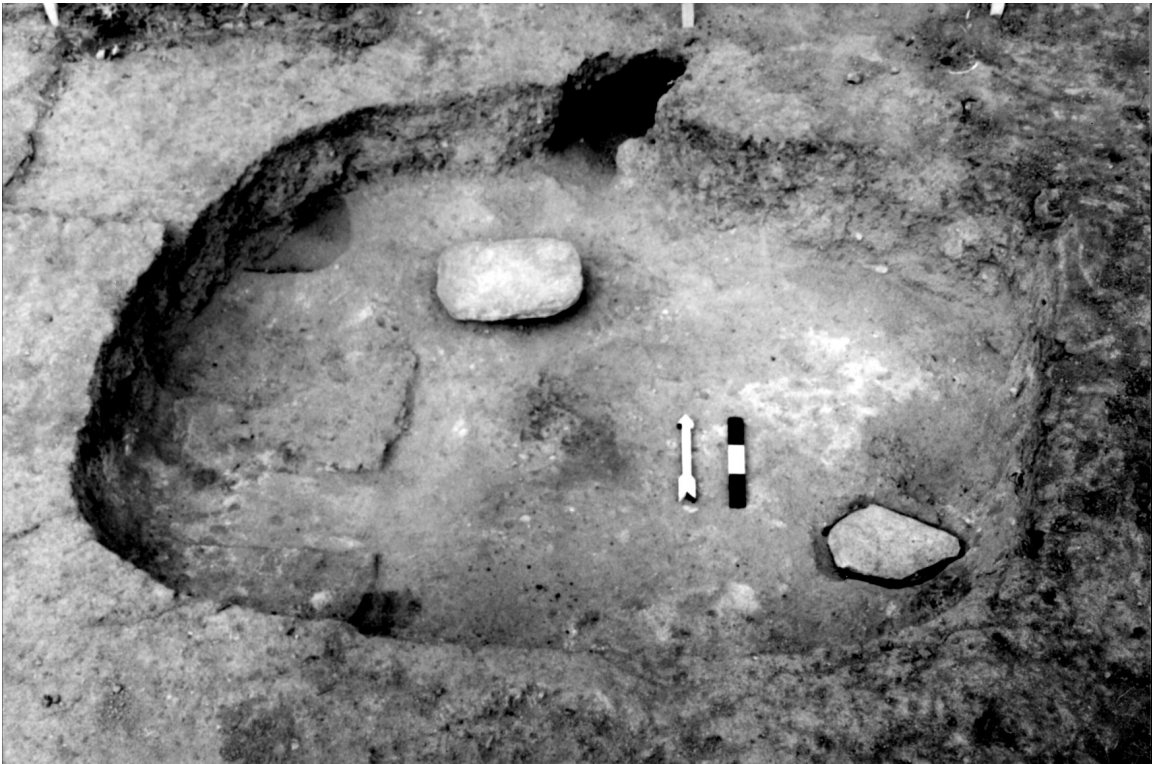

Figure 6. Pit Structure 1 overview. Note metate and mealing station against east wall. Rodent den cuts through north wall.

Stone-Ringed Hearth (Feature 1). A stone-ringed hearth was built over the southwest corner

of the pit structure (Fig. 7). The hearth overlapped Grids 98N/99E and 99N/99E. The feature was fully exposed at a depth of 8 cm below the surface, although two stones were initially visible at 2 cm below the modern surface. The circular hearth measured 40-by-40 cm with 12 cm of fill. The fill consisted of charcoal-stained soil with small charcoal fragments. Rodent activity had mixed charcoal from the hearth with the underlying fill of the pit structure. The hearth was constructed of 25 pieces of local granite averaging 10-by-10 cm. Artifacts were limited to a single burned peach pit suggesting an unknown historic affiliation. Another peach pit was discovered 8 m south of the hearth during testing. The project area has been the scene of Historic period activities since at least the 1785 founding of the Cañada de los Alamos Grant and continuing to modern times. Sheep and cattle grazing, travel, and camping were common activities during this 200-year period. Stone-ringed hearths and recent refuse are common features on the landscape (Viklund and Scheick 1989:7). The unknown historic component is probably associated with one of these short-term activities. The makers of the hearth most likely had no idea that a prehistoric pit structure was below their feet.

Storage Facility (Feature 2). This shallow pit is located 2 m northeast of the pit structure. The feature overlaps Grids 101N/103E and 102N/103E. The south edge of the feature was actually uncovered by Test Unit 101N/103E during the testing program, but the feature was not recognized at that time. The feature outline was delineated during the excavation program as the cultural layer was removed from the underlying natural alluvium. The large oval pit measured 130 cm east-west by 116 cm north-south and was fully exposed at a depth of 10 cm below the modern surface (Fig. 8). The unlined, flat-bottomed pit contained 8 cm of fill consisting of a homogeneous layer of brown sandy loam with infrequent charcoal flecks. The feature fill was indistinguishable from the surrounding cultural layer. A tabular sandstone slab measuring 25-by-25-by-5-cm thick was located in the center of the feature (Fig. 9). This apparent hatch cover was flaked around the edges into roughly a square shape and rested on fill about 1 cm above the floor. Artifacts consisted of four plain gray ware sherds, probably from the same vessel, and one chert core/hammerstone. A burned seed fragment was tentatively identified as either corn or juniper. Unfortunately, a definite identification was not possible from the poorly preserved undiagnostic fragment. Three pieces of fire-cracked rock were noted, but the absence of charcoal, ash, and oxidation suggests that the pit did not function as a thermal feature. The exact function of the shallow pit is unknown. The hatch cover and its position suggests an enclosed storage space with roof or upper wall access. The lack of other architectural remains suggests a nondurable “wikiup-like” superstructure that has decayed or melted. No postholes or superstructure sockets were recognized around the perimeter of the pit. The hatch cover was apparently left in place at abandonment, and the storage facility filled with about 1 cm of fill before the superstructure collapsed and the hatch fell to the floor. The burned seed may corroborate use as a storage facility, but rodent action is also evident in the feature.

Posthole (Feature 3). A remodeled posthole was found 2.5 m south of the pit structure in Grid 95N/99E. A roughly circular dark stain with several pieces of protruding granite was evident as the cultural layer was removed from the grid. The original posthole was about 10 cm in diameter and was dug about 30 cm into the natural alluvium (Fig. 10). The posthole tapered inward slightly and a natural piece of granite was at the base. The prehistoric inhabitants later removed the post by digging out the east side of the posthole. The original socket was packed with about 10 cm of cultural fill and a second slightly smaller 8- to 9-cm post was set in the shallower posthole. The second posthole had more of a cylinder-shaped profile. The post had been shimmed with several pieces of granite. The prehistoric inhabitants also reused the second post by digging out the east side of the posthole leaving a funnel-shaped profile.



Figure 7. Historic unknown period stone-ringed hearth (Extramural Feature 1) built over southwest corner of Pit Structure 1.



Figure 8. Extramural Feature 2, storage facility; note hatch cover resting in center of feature.

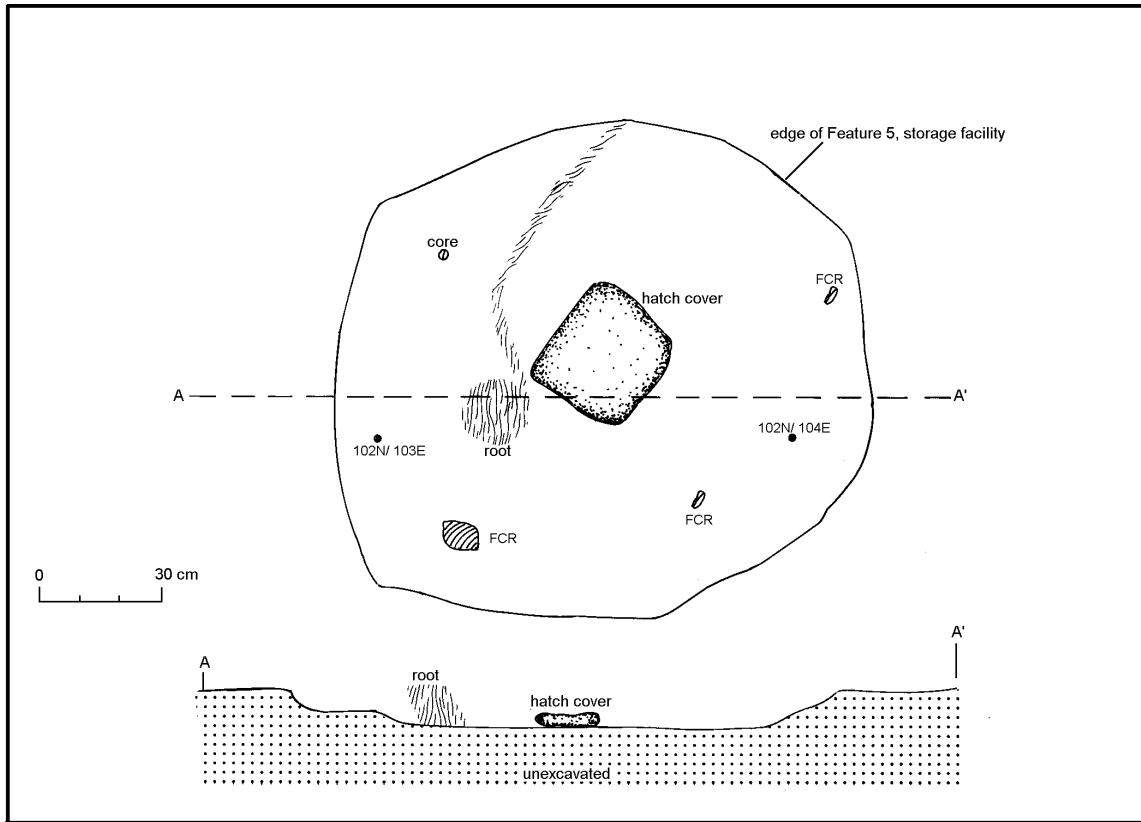
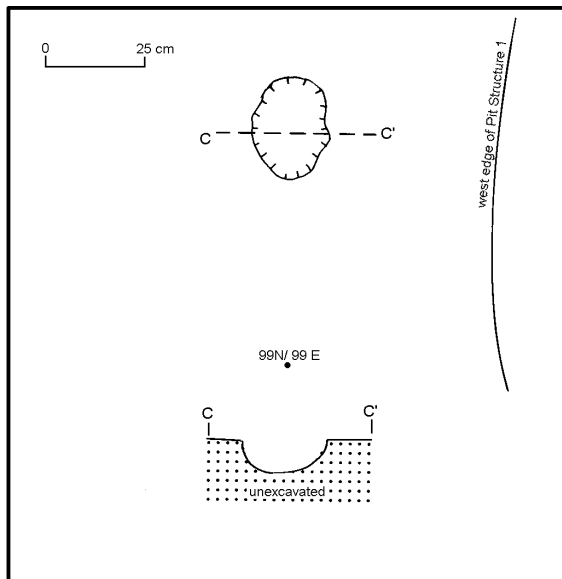

Figure 9. Plan and profile of storage facility, Feature 2.

The posthole was large and deep enough to have supported a rather substantial upright post. The posthole was probably associated with a ramada-like structure. Unfortunately, the remaining support posts for the ramada were not discovered. I expect the postholes would be located west or southwest of the surface stripped area, if they exist (Fig. 3). However, surface artifacts were infrequent in this area and there were no surface indications of cultural activities. A row of five contiguous test units sampling the nearby area revealed very shallow subsurface fill with minimal artifact content. In any event, the posthole suggests the presence of a ramada-like surface structure south of the pit structure. The shaded structure implies the need for hot weather shelter. The structure was remodeled at least once and was finally dismantled, possibly at site abandonment.



Pit (Feature 4). A shallow pit was found 30 cm west of the pit structure in Grid 99N/98E (Fig. 11). The feature appeared as an oval stain contrasting with the surrounding natural alluvium as the cultural layer was removed from the grid. The stain was fully exposed at a depth of 10 cm below the modern ground surface. The unlined pit measured 23 cm north-south by 18 cm east-west by 8 cm deep. The fill was identical to the surrounding cultural layer and no artifacts were recovered. The function of the nondescript pit is unknown. There was no evidence of thermal use, and the pit appears too shallow for a posthole. The hemispherical profile suggests use as a simple pot rest.

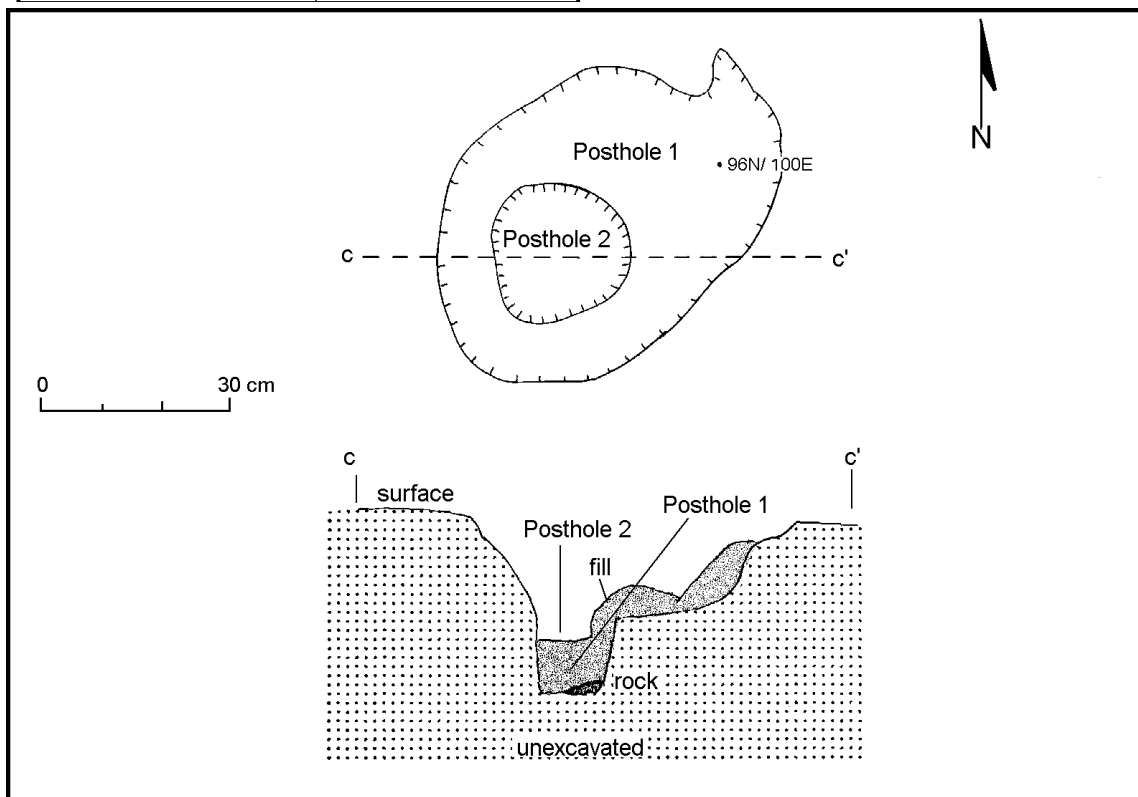

Figure 10. Plan and profile of Feature 3, posthole.

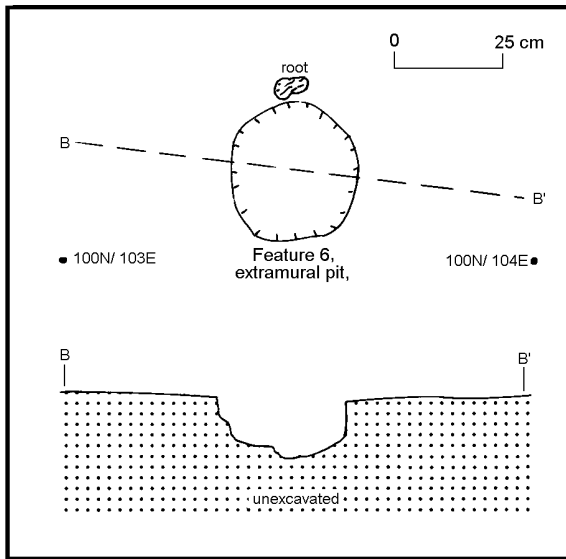

Figure 13. Feature 6, extramural pit; plan and profile.

Pit (Feature 6). This shallow pit was located just over 1 m east of the pit structure and 1.2 m south of Feature 1. The feature was found in Grid 100N/103E at a depth of 10 cm below the modern ground surface. The feature appeared as a dark stain contrasting with the surrounding natural alluvium. The circular, unlined pit measured 28-by-28 cm and was dug 12 cm into the natural alluvium (Fig. 13). The sides and bottom of the pit were irregular. The dark sandy loam fill was identical to the surrounding cultural layer. No artifacts were found, and cultural material was limited to a small charcoal fragment and small piece of burned adobe apparently from the roof of the nearby

Posthole (Feature 5). This posthole was found 30 cm south of the pit structure in Grid 98N/101E. The feature was originally exposed in Test Unit 98N/101E during the testing program, but the outline was not recognized at that time. Like the other extramural features, the posthole was evident as a dark stain contrasting with the surrounding orange natural alluvium. The stain was only discernible at a depth of 10 cm below the modern ground surface when the overlying cultural layer was completely removed from the grid. The circular posthole measured 20-by-19 cm and was dug 16 cm into the natural alluvium (Fig. 12). The posthole had a cylindrical profile and a nearly level bottom. The posthole does not appear deep enough to have supported an upright post, and may technically be categorized as a socket that employed some form of additional brace to help support the post (Wiseman 1995:61). The posthole is adjacent to the pit structure, but whether the post was associated with the pit structure architecture or roof is unclear.

The fill seems typical of the general dispersion of the occupation layer. The integrity of the fill has been affected by both rodent activity and large juniper roots. There was no evidence of thermal use. The function of this simple shallow pit is unknown.

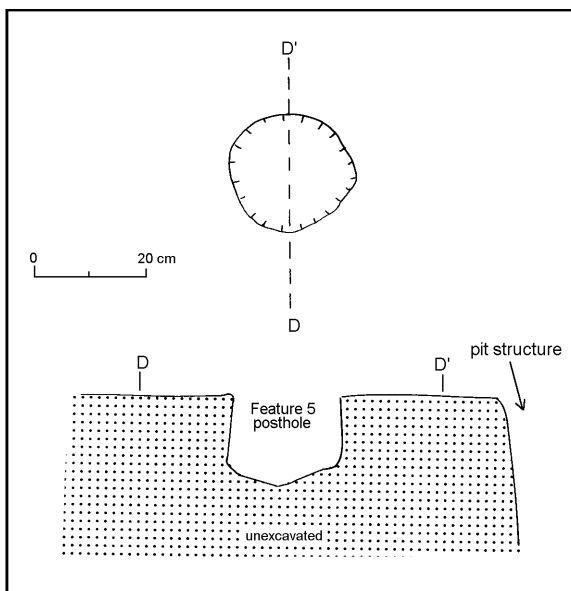

Figure 12. Feature 5, posthole; plan and profile.

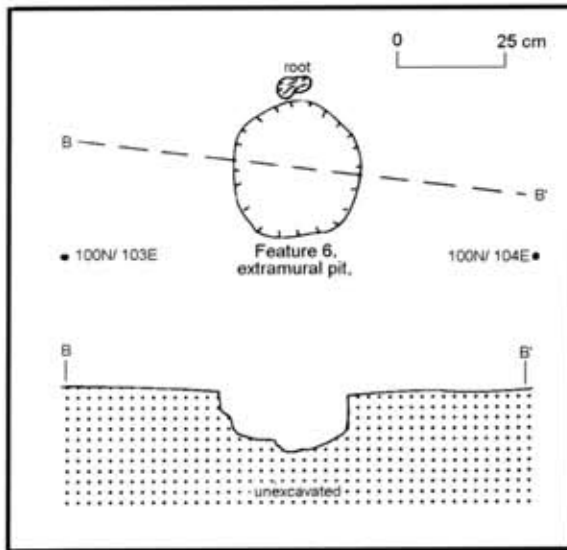

Figure 13. Feature 6, extramural pit; plan and profile.

use. The function of this simple shallow pit is unknown.

Pit (Feature 6). This shallow pit was located just over 1 m east of the pit structure and 1.2 m south of Feature 1. The feature was found in Grid 100N/103E at a depth of 10 cm below the modern ground surface. The feature appeared as a dark stain contrasting with the surrounding natural alluvium. The circular, unlined pit measured 28-by-28 cm and was dug 12 cm into the natural alluvium (Fig. 13). The sides and bottom of the pit were irregular. The dark sandy loam fill was identical to the surrounding cultural layer. No artifacts were found, and cultural material was limited to a small charcoal fragment and small piece of burned adobe apparently from the roof of the nearby pit structure. The fill seems typical of the general dispersion of the occupation layer. The integrity of the fill has been affected by both rodent activity and large juniper roots. There was no evidence of thermal

MATERIAL CULTURE

Site excavation recovered 230 artifacts consisting of 185 sherds, 24 pieces of chipped stone, 18 animal bone fragments, and 3 pieces of ground stone (Table 4). An additional 25 sherds, 5 pieces of chipped stone, and 1 animal bone fragment were recovered during the testing program. These artifacts are included with the various assemblage discussions. The surface, surface strip, and cultural layer are arbitrary excavation divisions of the general prehistoric occupation layer. No appreciable differences were noted between the vertical proveniences and they can be combined for discussion. Similarly, no appreciable differences were observed between the general fill and roof fill of the pit structure. These excavation proveniences can be combined and discussed simply as pit structure fill.

Table 4. Artifact Types by Major Provenience

PROVENIENCE	ARTIFACT TYPE				
	Chipped Stone	Ground Stone	Ceramics	Faunal	Total
Surface	5		12		17
Surface Strip	5		67	1	73
Cultural Layer	7	1	30	15	53
Pit Structure 1	6	2	72	2	82
Extramural Feature 2	1		4		5
TOTAL	24	3	185	18	230

Faunal Assemblage

Eighteen faunal fragments were recovered during excavation and an additional jackrabbit bone was collected during the testing program (Table 5). The 19 fragments in fact represent pieces of 12 discrete elements. The elements in turn can be attributed to five individual animals including two mule deer, one pronghorn, one cottontail rabbit, one jackrabbit, and one medium mammal. Elements from most of the individuals exhibit evidence of butchering and various degrees of burning indicating roasting and final discard into a fire pit. The majority of the fragments (n = 15) were recovered from the cultural layer in three adjacent grids west of the pit structure. The cultural layer was 15 to 20 cm thick in this area and seemed to characterize a light midden accumulation.

I assign the entire small faunal assemblage to the primary Coalition period component, although the presence of the unknown historic hearth introduces a degree of uncertainty. The range of bone and the discard into a midden context with chipped stone artifacts and sherds seems more indicative of the prehistoric component rather than what would be expected with the short-term historic component. Much of the bone exhibits burning, but no prehistoric thermal features were found other than the informal hearth in the pit structure. The charcoal infused cultural layer with occasional fire-cracked rock indicates that fire was frequently used, but formal thermal features have not survived in the investigated site area. The only thermal feature found on the site was the historic hearth, but no burned bone was found in the fill. The paucity of charcoal and ash suggests a single burning episode such as a one-night camp, yet many of the burned bone fragments indicate initial discard into a smoldering fire. I doubt that the fill of the historic hearth was ever cleaned out and dumped as secondary refuse. Further, the variety of animals does not correspond with the historic camp site. I therefore cautiously assign the small faunal assemblage to the prehistoric occupation.

The faunal assemblage indicates that the prehistoric inhabitants were hunting animals commonly found in the local environment. Mule deer, pronghorn, and rabbits are still commonly observed in the area even with the large housing developments. The small number of animals suggests that

hunting and meat consumption were not primary site activities. Of interest, considering the small assemblage, is the larger number of deer-sized animals compared with only two rabbits. Both mule deer are young or immature individuals that would have been procured during early summer (around June). Lang (1992:52) recovered 91 bone fragments from a contemporary fieldhouse about 1.5 km north of LA 115266. Of these, 75 were from medium- to large-bodied mammals. Lang (1992:51-52) also recovered a bone awl and scraper suggesting that hide processing was a site activity in addition to hunting and meat consumption. No worked bone was found at LA 115266. The small faunal assemblage indicates the low-level procurement and consumption of common local mammals, which corresponds with an occupation of short duration and low intensity.

Table 5. LA 115266 Faunal Assemblage

FS-LOT	PROVENIENCE	TAXON	ELEMENT	AGE	COMMENTS
11-1	Testing 98N 101E Level 1	<i>Lepus californicus</i> Jackrabbit	R innominate; Most of ilium and acetabulum	Mature	Partial burning; Broken into several pieces, fresh breaks
32-1	Surface strip 102N 101E	Medium artiodactyl (deer or pronghorn size)	Rib shaft fragment	Young adult; porous	Calcine
60-1	Cultural layer 99N 98E	<i>Odocoileus hemionus</i> Mule deer	R proximal tibia epiphyses	Young adult, epiphysis	2 pieces, old break
60-2		Medium artiodactyl (deer or pronghorn size)	R proximal radius fragment	Mature	Impact fracture, shaft just below proximal end; rodent gnawing around proximal end; checked; fresh breaks; possibly pathological or malformed medial portion
60-3		<i>Odocoileus hemionus</i> Mule deer	R mandible; most of ramus and small body fragment	Neonate to very immature	Same mandible as 63-1
60-4		Large mammal (sheep or larger)	Long bone shaft fragment	Mature	Exfoliating
61-1	Cultural layer 100N 98E	<i>Antilocapra americana</i> Pronghorn	R metatarsal, distal end and 20% of shaft	Mature	Impact fracture above distal end
61-2		<i>Sylvilagus</i> sp. Cottontail rabbit	L innominate; acetabulum and parts of ischium and ilium	Mature	Burned dark brown; 2 pieces, fresh break
61-3		Medium mammal (between jackrabbit and wolf in size)	Long bone shaft fragment	Immature; porous	Environmental pitting; 2 probably cuts perpendicular to shaft
63-1	Cultural layer 100N 97E	<i>Odocoileus hemionus</i> Mule deer	R mandible dp4 and dp3	About 2.5 to 4 months	Same mandible as 60-3; 3 pieces fresh break
63-2		Medium artiodactyl (deer or pronghorn size)	Long bone shaft fragments – tibia?	Mature	2 pieces from same element; impact fracture, midshaft
90-1	Pit structure 1 general fill	Large mammal (sheep or larger)	Long bone shaft fragment	Mature	Burned brown
93-1	Pit structure 1 general fill	<i>Antilocapra americana</i> Pronghorn	R calcaneus; posterior portion	Mature	Mostly burned, black

Ground Stone Assemblage

The ground stone assemblage consists of a slab metate and a one-hand mano. The slab metate was constructed from a local granite slab flaked into a roughly rectangular shape measuring 41.5 cm long by 26.8 cm wide by 6.0 cm thick, and weighing 12.7 kg. The metate was the only artifact found on the floor of the pit structure. The metate was originally associated with a mealing station built against the east wall of the pit structure. The metate had been moved and abandoned near the north wall. The site inhabitants had apparently considered taking the metate with them at abandonment, but changed their minds as the thought of hefting the metate up the entrance ladder was contemplated. However, no two-hand manos were found on the site. The slab metate replaced the earlier troughed varieties during the Coalition period (Wendorf and Reed 1955:145). Slab metates were the most common type recovered at Arroyo Hondo Pueblo, and they are closely associated with corn grinding (Phagen 1993).

A complete one-hand mano is represented by two fragments recovered from two separate proveniences. The one-hand mano was made from a medium-grained sandstone cobble measuring 9.8-by-9.4-by-3.8-cm thick, and weighing 545 g. The well-shaped circular mano exhibits pecking around the perimeter and on one face. The mano has a biconvex cross section with polish on both faces. One fragment from Grid 98N/101E, cultural layer, was found near the south edge of the pit structure. This fragment was burned, possibly from the recent tree burns noted on the site. The other half of the mano was unburned and was found in the west half of the pit structure's general fill. The one-hand mano fits into the size range of regional Archaic manos (Post 1998:68). The mano is apparently an Archaic artifact collected and used secondarily by the Pueblo inhabitants in plant processing activities. The polish suggests either original or secondary use in architectural maintenance activities, such as a floor polisher. One face of the mano exhibits rejuvenation pecks, which may have resulted in the fracturing of the mano. The mano was discarded with other light refuse in the fill of the pit structure.

Chipped Stone Artifacts

by Jessica Badner

Twenty-nine chipped stone artifacts were recovered from LA115266. They make up 11 percent of the site's total artifact assemblage. The chipped stone assemblage is made up of 18 core flakes, 5 formal tools, 2 informal tools (one core flake, one core hammerstone), 1 biface flake (an *outré passé* which includes the lateral portion of a biface), 1 core, and 2 pieces of angular debris. Material types include chert, obsidian, chalcedony, basalt, quartzite, quartz, and silicified wood. This assemblage was analyzed in accordance with the *OAS Standard Lithic Artifact Analysis: Attributes and Variable Coding List* (Office of Archaeological Studies Staff 1994).

Analytical Framework

Two basic reduction strategies have been used in the Southwest to interpret chipped stone patterns (Moore 1994). These strategies are based on expectations of forager and collector models proposed by Lewis Binford in the 1970s and early 1980s. Curated strategies are associated with residential mobility while expedient strategies are linked to long-term residential stability (Binford 1977, 1979, 1980; Kelly 1988; Camilli 1989; Bamforth 1991; Ebert 1992; Andrefsky 1994). Curated strategies are characterized by large biface manufacture and emphasize the production of the maximum usable length of edge per core. Flakes created during biface manufacture can be used as tools themselves

and therefore reduce the amount of wasted material. More effective tool manufacture, in turn, reduces the amount of raw material that has to be transported or obtained from a base camp. In contrast, expedient strategies are not affected by the necessity of material transport, and raw material is not used as efficiently (Moore 1994; Kelly 1988; Camilli 1989; Bamforth 1991; Ebert 1992; Andrefsky 1994). During expedient reduction, flakes are removed from cores as needed. It is expected that a lithic assemblage from a site with a sedentary or agricultural population would be dominated by debris from expedient core reduction. Comparatively, an assemblage collected from a site with a more mobile population, such as a hunter-gatherers', should display evidence of more efficient core reduction and use of raw materials (Post 1996).

Materials

Artifacts in this assemblage were separated into 12 different material types, which included local and nonlocal materials (Table 6). Local raw materials are defined as those materials available within a day's journey or within a 10- to 15-km radius of LA 115266 (Kelly 1994). Some of the local raw materials collected at LA115266 were available in the Ancha Formation along the Arroyo Hondo and the eastern Galisteo Basin. Undifferentiated chert is the most common followed by quartzite, chalcedony, and silicified wood (Post 1999). Basalt is common in the area as well and may have come from such sources as the Cerros del Rio basalt flows, White Rock Canyon, or the gravels of the Rio Grande (Warren 1979:50-51). Other local material such as red jasper and quartz are probably from the Galisteo or Santa Fe basins (Lang 1992).

Nonlocal materials are most strongly represented by obsidian from the Jemez Mountains (20 percent of this assemblage), which was commonly used for tool production at Pueblo Alamo (LA 8), approximately 2 km to the north (Allen 1973, plates 9 and 10; Lang 1992). Three of the five formal tools and one of the informal tools in this assemblage are made from Jemez obsidian. Polvadera Peak obsidian, also from the Jemez Mountains, is found in this assemblage and represents one of the four formal tools collected at LA115266. Like Jemez and Polvadera obsidian, Pedernal chert also occurs in this assemblage at a relatively high frequency. Although the Pedernal formation is located in the Chama Valley, the chert is also found in the axial gravels of the Rio Grande and may be found as far south as Las Cruces. It is impossible to tell without the presence of a cortical surface where the material originated, but it is likely that examples in this assemblage were obtained from secondary gravels of the Rio Grande. For the purposes of this analysis, Pedernal chert is considered a local material (Appendix 2; Post 1998).

Chipped Stone Artifact Analysis

All chipped stone artifacts were examined using a standardized analysis format developed by the Office of Archaeological Studies (OAS Staff 1994) in an attempt increase comparability between projects completed across the state. The OAS chipped stone analysis format includes a series of attributes that describe material, artifact type and condition, cortex, striking platforms, and dimensions (Appendix 2).

The primary areas this analysis explores are material selection, reduction technology, and tool use. These topics provide information about ties to other regions, mobility patterns, and site function. While material selection studies cannot reveal *how* materials were obtained, they can usually provide some indication of *where* they were procured. By studying the reduction strategy employed at a site, it is possible to compare how different cultural groups approached the problem of producing useable chipped stone tools from raw materials, and how the level of residential mobility affected reduction strategies. The types of tools present on a site can be used to help assign a function, particularly on

artifact scatters lacking features. Tools can also be used to help assess the range of activities that occurred at a locale. In some cases, chipped stone tools provide temporal data, but unfortunately they are usually less time-sensitive than other artifact classes like pottery and wood.

Each chipped stone artifact was examined using a binocular microscope to aid in identifying morphology and material type, examine platforms, and determine whether it was used as a tool. The level of magnification varied between 20x and 100x, with higher magnification used for wear-pattern analysis and identification of platform modifications. Utilized and modified edge angles were measured with a goniometer; other dimensions were measured with a sliding caliper. Analytical results were entered into a computerized database using the *Statistical Package for the Social Sciences Data Entry* program. See Appendix 2 for definitions of artifact classes, type and quality, artifact morphology, and function.

Distribution

Table 6 illustrates the relationship among material, artifact type, and provenience in which artifacts were found. Although the assemblage size is small, some important trends can be identified.

Excavation of the cultural layer yielded 10 pieces of chipped stone, the highest artifact count as well as the most diverse artifact morphology of any stratum at LA 115266. With an equal number of tools and core flakes, the cultural layer contains 60 percent of tools at this site as well as one core and a piece of angular debris. Core flakes are made of chert and silicified wood. The cultural layer is also the source of the largest amount of nonlocal material, all of which is associated with tool manufacture.

Surface collection, Pit Structure 1, fill, and surface strip each yielded six artifacts. The majority of artifacts recovered during surface collection are core flakes with no dorsal cortex. Material type in this layer is dominated by chert, all of which could have been procured locally. Core flakes with less than 10 percent dorsal cortex dominated Pit Structure 1, fill, artifact morphology. In addition, this fill contains one piece of angular debris. Pit Structure 1, fill, is unique in that material types are limited to quartzite and obsidian. Three of the five core flakes are made of the same type of fine-grained gray quartzite, which suggests that they may be debitage from a single reduction episode. Their location in the roof fill and general fill argues that some of the pit structure fill may have been dumped into the collapsed structure (Moore 1999).

Surface strip, which to some extent can be seen as an extension of surface collection, was the last major source of chipped stone artifacts at LA 115266. Although secondary core flakes were most common in this fill, artifact morphology in this layer was more varied with a higher percentage of tools than in surface collection. Core flakes are manufactured from a wider range of materials, including chert, basalt, and quartz. In addition, surface collection yielded the only primary core flake on site with 100 percent cortex as well as the only biface flake at LA 115266. Formal and informal tools are made from Pedernal chert and undifferentiated obsidian.

The last source of chipped stone artifacts came from extramural feature fill in Feature 2. The artifact is a core-hammerstone made of undifferentiated chert.

Table 6. Chipped Stone Artifacts and Material Types by Provenience

Stratum	Surface	Surface Strip	Cultural Layer	Structure 1 fill	Feature 2	Subtotal	Type Total
Artifact Type	Material						
Projectile Point	Jemez Obsidian			2			2
	Polvadera Obsidian			1			1
	Pedernal Chert			1			1
							4 (14%)
Debitage, utilized/retouched	Chert	1					1 (3%)
Debitage, unidirectional retouch	Pedernal chert		1				1 (3%)
Biface flake (outré passé)	Jemez obsidian		1				1 (3%)
Core-hammerstone	Chert					1	1 (3%)
Core	Chert			1			1 (3%)
Core flake	Obsidian	1*					1
	Jemez obsidian		1		2		3
	Chert			2 (1*)			2
	Pedernal chert			1			1
	Red chert		1	1			2
	Chalcedonic chert	1					1
	Calcedony	1					1
	Silicified wood			1			1
	Basalt		1				1
	Quartz		1				1
	Quartzite	1			3		4
							18 (62%)
Angular debris	Obsidian				1		1
	Chalcedony			1			1
							2 (8%)
Total		6 (21%)	6 (21%)	10 (34%)	6 (21%)	1 (3%)	29 (100%)
							29 (100%)

* indicates thermal alteration

Table 7. Chipped Stone Artifact Morphology and Material Type

	Projectile Point	Debitage Utilized/Retouched	Debitage Unidirectional Retouch	Biface Flake (outré passé)	Core	Core-Hammerstone	Core Flake	Angular Debris	Total/Percent
Obsidian							1	1	2 6.8
Jemez obsidian	2			1			3		6 20.7
Polvadera obsidian	1								1 3.4
Chert		1			1	1	2		5 17.2
Pederal chert	1		1				1		3 10.3
Red chert							1		1 3.4
Chalcedonic chert							2		2 6.8
Chalcedony							1	1	2 6.8
Silicified wood							1		1 3.4
Basalt							1		1 3.4
Quartz							1		1 3.4
Quartzite							4		4 13.8
Total Percent	4 13.8	1 3.4	1 3.4	1 3.4	1 3.4	1 3.4	18 62.0	2 6.8	29 100%

Artifact Morphology

The chipped stone assemblage is dominated by core flakes; 17 of the total (n = 18) are secondary flakes, one is a primary flake (Table 7). Primary flakes are flakes with 50-100 percent cortex on their dorsal surfaces, and secondary flakes have less the 50 percent. In this assemblage, all but one of the secondary flakes have no cortex. In contrast, only one primary flake with 100 percent waterworn cortex was found on site. Seven of the 18 core flakes have broken or missing platforms. None of the 18 core flakes have modified platforms. Six platforms are single facet and only 3 of the 18 have multifaceted platforms. The remaining two flakes have either a collapsed or crushed platform. Seven of the 18 flakes are whole and 4 are medial. Two of the 4 medial flakes exhibit manufacturing breaks at their distal terminations. There are an equal number of both proximal and distal flake fragments (3 each) and all but 1 of them exhibit snap fractures. This flake is also the only one with a multifaceted platform. No flakes in this assemblage have opposing dorsal scars. Eleven of the 12 material types are represented, 12 of the 18 flakes are made of local material, and 3 of the 4 obsidian flakes are made of Jemez obsidian.

One of the core flakes recovered during testing is a modified core flake of red chert that was probably used as a scraper. The tool exhibits unidirectional retouch on one margin and has an edge angle of 60 degrees. Heavy step fractures along this edge indicate that the tool was repeatedly used on hard or very rough materials such as coarse fiber or wood (Post 1999; Schutt 1983).

Angular debris was a less common form of debitage found at LA 115266. Two pieces of angular debris were found. One found in the fill of the pit structure is obsidian and is heavily patinated with

Table 8. Chipped Stone Tools

Stratum	FS	Function	Material	Portion	Length (mm)	Width (mm)	Thickness (mm)	Edge Angle in degrees
Surface	1 (testing)	Utilized / retouched debitage	Chert	Distal	22	30	7	60
Surface Strip	39	Possible scraper	Pedernal chert	Distal	3	26	8	26
Cultural Layer	62	Biface preform	Jemez obsidian	Distal	22	17	3	24,31
Cultural Layer	65	Biface late stage	Pedernal chert	Medial	18	12	4	49,46
Cultural Layer	67	Biface, middle stage	Jemez obsidian	Distal	17	10	2	24,21
Cultural Layer	7 (testing)	Biface, late stage	Polvadera obsidian	Proximal	17	15	5	
Cultural Layer	113	Core-hammer-stone	Chert	Whole	57	44	36	N/A

rounded edges and may be evidence of scavenged obsidian from earlier sites. The other was recovered in the cultural layer during testing and has 60 percent waterworn cortex.

Only one biface flake and two chert cores were recovered from LA 115266. Made of local chert, one core is extensively reduced angular debris with no remaining cortical surface. In addition to being exhausted, this multifaceted core is also small in size, measuring only 27 mm long by 19 mm wide by 11mm thick. The other core is an extremely battered chert core-hammerstone with no remaining cortex. This multidirectional core was probably rejected when too many step and hinge fractures accumulated due to flaws in the material. Rather than abandoning the core, it was reused as a hammerstone. The biface flake of Jemez obsidian was created by an outre passé break on a biface, a lateral portion of the biface edge still remains. Low biface flake counts could be partially attributed to field methods. The cultural layer was screened through ¼-inch mesh. If ⅛-inch hardware cloth had been used, a few more biface flakes may have been found in the cultural layer. On the other hand, the scarcity of debitage in the pit structure and feature fill, which was screened through ⅛-inch mesh, argues that biface flake density at this site is extremely low, regardless of recovery methods.

The second most common artifact type from LA 115266 is formal tools. Table 8 shows the tool assemblage by raw material type and stratum. Three of the five formal tools are made from nonlocal, or in the case of Pedernal chert, scarce material. Informal tools are manufactured from local materials.

FS 39 may be the distal end of a broken scraper. Made of Pedernal chert, this tool exhibits unidirectional retouch but no visible wear. Although the broken edge of the tool cannot be conclusively identified as a manufacturing break, the absence of visible wear suggests that it may have been broken during production and abandoned. The edge angle measures 42 degrees.

FS 62 is a biface preform. Made of Jemez obsidian, this tool is bifacially retouched on only the proximal end and one lateral edge. No signs of utilization are visible. Edge angles measure 24 and 31 degrees, respectively.

FS 65 is the medial portion of a small, undifferentiated late stage projectile point. Made of Pedernal chert, this point exhibits snap fractures at its proximal end and a possible impact fracture at its tip. The impact fracture suggests evidence of hunting at LA 115266. Edge angles measure 24

and 31 degrees.

FS 67 is the distal portion of an undifferentiated middle stage projectile point. Made of Jemez obsidian, this point was abandoned when it was broken during manufacture. This point measures slightly less than 2 mm at its thickest section and flake scars do not reach the medial flake axis suggesting that it was made on a very thin blank or possibly a scavenged core flake. Edge angles measure 24 and 24 degrees.

FS 7 (testing) is the distal portion of an undifferentiated late stage biface. It is the only artifact of Polvadera obsidian recovered on site. One surface of the tool fragment is flawed. This flaw interrupted flake scar termination, which eventually lead to breakage and discard. It is possible that this tool was brought to the habitation site in an unfinished or broken condition and was discarded when more raw materials became available.

Conclusion

Comparisons of material type and stage of lithic reduction in this assemblage reveal some interesting information concerning material acquisition and use. There is very little evidence for biface manufacture on this site. In fact, many of the core flake attributes in this assemblage suggest that little or no biface reduction occurred. None of the core flakes in this assemblage has modified platforms, indicating that platforms were not being prepared to facilitate flake removal. In addition, none of the flakes has opposing dorsal scars, which suggests that they were not being removed from a tool with an opposing edge such as a biface. Both core flakes and cores on this site lack dorsal cortex. The high number of secondary flakes and the extremely low percentage of cortex on both cores and flakes suggest that cores were brought to the site in a partially reduced state and then carried off (Lang 1992; Moore 1999). In addition, the over all ratio of debitage to tools on this site is low and there is almost no angular debris. In fact, artifact density is low. Chipped stone was found in only 5 of the 24 grids in which the cultural layer was removed. One grid contained 3 pieces of chipped stone and the remaining 4 grids were limited to 1 artifact each. Any midden to the east of the structure would have been destroyed by previous road construction. Even so, if there was extensive reduction taking place at this site, the absence of a midden could not fully account for the low artifact frequencies.

Evidence supporting biface reduction and tool use is limited. Other than a low number of manufacturing breaks, evidence is largely provided by one biface flake with an *outré passé* break and by manufacture breaks on the bifaces. One middle stage biface was broken in manufacture, another is a preform. Both bifaces and one broken unutilized scraper may have been made on site. Two late stage bifaces exhibit either use breaks or snap fractures. Evidence of formal tool use is limited to an impact fracture at the tip of a projectile point. Evidence of informal tool use consists of a scraper found during testing and an extremely battered core-hammerstone.

Procurement patterns at LA 115266 are characteristic of an expedient reduction strategy. Although cores were brought to the site in a partially reduced stage, the cores themselves were not formal tools. Lack of biface flakes, retouched platforms, or an even number of proximal and distal flake fragments imply that the most common form of reduction at LA 115266 was on core flakes for potential use as tools. Limited core reduction coupled with low artifact densities imply that this site was not inhabited intensively and may have been occupied seasonally. Based on the chipped stone assemblage, activities that site inhabitants may have participated in include hunting, butchering, and leatherwork. This pattern also suggests that the inhabitants of LA 115266 benefitted from their close proximity to Pueblo Alamo. Informal tools manufactured from core flakes of locally available material probably augmented the use of late stage formal tools made of more exotic or potentially rare material. Lack of debitage and biface flakes discussed above suggest that these late stage bifaces

or preforms may have been brought to the site from Pueblo Alamo or other nearby habitation areas.

Comparison with LA 75680

LA 75680 was excavated by Dick Lang in 1989. Situated on a ridge southeast of Cañada de los Alamos and located 1.3 km northwest of LA 115266, LA 75680 could date to the Archaic, Basketmaker, late Developmental, or early Coalition period. The site had a jacal fieldhouse located on the southern ridge top. Lang (1992) states that this component of the site was probably linked with Pueblo Alamo. The early activity areas were located at the north end of the site. This comparison will focus on chipped stone from the south knoll concentration. By focusing on the south knoll, mixing of noncontemporaneous assemblages may be minimized.

Only 36 pieces of chipped stone from the south knoll concentration were analyzed, 8 of which were patinated. Because Lang associated patination with relative artifact age and since there is an earlier component to this site, it could be argued that these artifacts should not be included in the south knoll artifact sample. On the other hand, statistics are unaffected by the removal of the patinated portion from this assemblage. Since patina formation can affect stratigraphic context and site depositional history (Lang includes a lightly patinated argillite point in artifacts associated with the jacal structure), the patinated artifacts will be counted as associated.

Lang reports seven formal tools and five utilized flakes. Formal tools include two black argillite points, two obsidian points, one Madera chert drill, one knife-hammerstone of gray cherty chalcedony, and one Madera chert strike-a-light fashioned from an abandoned scraper. Utilized flakes include three made of obsidian and two of chalcedony. The remaining pieces of chipped stone are unutilized flakes and angular debris. Formal tools account for 14-16 percent of the south knoll assemblage, utilized flakes for 13-15 percent, and flakes and angular debris for 70 percent (Lang 1992). Frequencies are similar to those of the LA 115266 assemblage, where formal tools account for 17 percent of chipped stone, 6 percent are informal tools, 3 percent are cores, and 73 percent are angular debris and unutilized core flakes.

It is important to note here that differences in interpretation have an affect on the results of the formal tool counts as well as material use interpretations. According to the OAS system, depending on the individual artifacts, both strike-a-light flints and a knife-hammerstone could be assigned to the informal tool category. Likewise, according to Moore's interpretation, a strike-a-light would be temporally unrelated to this assemblage.

Material types at LA 115266 and LA 75680 differ with respect to chert and argillite. Lang reports a high percentage of white chert in his assemblage (38 percent) and probable Madera chert (16 percent), both of which are minimally present in the LA 115266 assemblage. He also reports argillite and Tecolote chert, which were not identified at LA 115266. When lumped together however, cherts (all of them local) account for 57 percent of the south knoll lithic assemblage and 45 percent of the chipped stone at LA 115266. Obsidian is less common on the south knoll than at LA 115266 (16 percent versus 23 percent) and its correlation to formal tool production is not as strong—only 25 percent of the formal tool assemblage versus 60 percent at LA 115266. Remaining material percentages follow: argillite, 11 percent; quartzite, 5 percent; basalt, 3 percent; and silicified wood, 3 percent.

Lang's tool assemblage does not support the correlation between the use of exotic or potentially hard to find materials and the manufacture of formal tools. However, artifact morphology does support evidence of activity specialization and a possible economic link to Pueblo Alamo (Lang 1992). As a whole, the LA 75680 assemblage reflects a focus on secondary core reduction.

Noticeably low frequencies of lithic debitage, biface flakes, and cores coupled with relatively high frequencies of secondary flakes with very little or no cortex suggest that, over all, cores were brought to the site in an partially reduced state, used, and then taken elsewhere (Lang 1992).

When comparing the assemblages from LA 75680 and LA 115266, certain similarities are apparent. Both sites have extremely low artifact counts indicating that core reduction was extremely limited. Both assemblages have a high frequency of formal tools indicating hunting and related processing activities went on at both locales. The ratio of tools to debitage in the assemblage further suggests that there is not enough debitage to support evidence of tool manufacture. The extremely low incidence or absence of cores on both sites also supports the argument that tool production on at each site was expedient. Most formal tools or blanks were brought from elsewhere, possibly Pueblo Alamo, used until they were exhausted or broken, then replaced by another imported tool or blank. When formal tools were exhausted or otherwise not available, flakes were utilized until another tool or blank could be procured.

Ceramics by C. Dean Wilson

This section presents information and interpretations resulting from the analysis of 197 sherds recovered during recent investigations by OAS of LA 115266. In order to determine the period and nature of the occupation of this site, a variety of data were recorded. These include associated provenience, descriptive attributes, typological categories, counts, and weights. Sherds were linked to a particular provenience by recording associated field specimen (F.S.) numbers. Quantitative data recorded for each line included total count and weight (Table 9).

Attribute Analysis

Descriptive attributes recorded for all sherds included temper, pigment, slip, vessel form, and modification. In addition, information such as refired paste color and decorative styles were recorded during a special analysis of selected sherds.

Temper. Temper refers to aplastic particles either intentionally added to the clay or natural clay inclusions serving the same purpose as added temper. Temper categories reflect distinctive combinations of color, shape, size, fracture, and sheen of observed particles. It is often impossible to differentiate rock types based on microscopic analyses of temper fragments.

Granite with mica refers to the dominant tempering material employed in gray ware vessels produced in much of the Northern Rio Grande, where local alluvial clays and granite sources from igneous formations or gravel sources ultimately derived from the Sangre de Cristo Mountains. Sherds containing this temper are usually easy to recognize because of the presence of numerous mica fragments visible through the vessel surface. Temper fragments are relatively large and subangular to sub-rounded in shape. These particles are usually white but occasionally are clear, light gray, or pink, and may include some black fragments. They include medium-sized quartz, feldspar grains, and brown biotite common in local granite sources.

Fine tuff or ash refers to the presence of fine volcanic fragments presumably derived from ash or tuff deposits. This category consists of small, clear, dark vitreous, angular to rod-shaped quartz and other particles, and light-colored dull pumice particles. The presence of such particles may indicate either the use of self-tempered ash-derived clays or the addition of crushed or weathered tuff or ash to the clay. Similar temper occurring along with numerous silt or fine sand fragments was

placed into a fine tuff and sand category.

Sand refers to rounded or sub-rounded, well-sorted sand grains. These fragments are transparent, white to gray in color, and may be frosted. This category is distinguished from sandstone temper by the presence of large, even-sized quartz grains, and the absence of a matrix. A few sherds exhibited large, distinct, vitreous subangular to rounded grains and is similar to temper informally referred to as anthill sand. These grains are often transparent or crystalline in structure, and generally occur in a nonmicaceous paste. This temper appears to be common in utility wares found in some areas of the Pajarito Plateau, and represent quartz phenocrysts occurring in tuff particles sorted and carried into anthills. A few examples contained sand temper in a paste with large, dull, rounded shale fragments and were assigned to a shale and sand category. Cases where tempering material was limited to very fine sand or silt fragments were assigned to a fine sand category. Examples with this temper in a micaceous paste were assigned to a fine sand with mica category.

Sherd temper refers to the use of finely crushed pot sherds as temper. Crushed sherd fragments are usually white, buff, gray, or orange in color. These fragments are often distinguished from crushed rock tempers by their dull nonreflective appearance. Small reflective rock particles may be included inside or outside the sherd fragments. In some cases, the presence of fairly large particles along with crushed sherd may indicate the addition of both crushed rock and sherd. Cases where both crushed pot sherds and sand occurred were assigned to a sherd and sand category. In a few examples, sherd temper was noted in a paste with numerous large, dull, rounded shale fragments. Such cases were assigned to a shale and sherd category.

Pigment Type. Pigment categories allude to the presence, surface characteristics, and color of painted decorations on each surface. Most pigments were divided into organic and mineral pigment groups based on appearance (Shepard 1963).

Mineral pigments refer to painted decorations applied in ground minerals, usually iron oxides. These are applied as powdered compounds, often with an organic binder. The pigment is a physical layer and rests on the vessel surface. Mineral pigments are usually thick and exhibit visible relief. Mineral pigments obscure surface polish and irregularities. The firing atmosphere, to which iron-based mineral pigments were exposed, affects color. Those fired in a neutral or reduction atmosphere are black, while those fired in an oxidizing atmosphere are reddish in color.

Organic pigments refer to the use of carbon or vegetal pigment only. Organic paint soaks into the vessel surface. Streaks and polish are often visible through the paint. The painted surface is generally lustrous, depending on the degree of surface polishing. Decorations in organic pigment may be gray, black, bluish, and occasionally orange in color. The edges of the painted designs range from sharp to fuzzy, and decorations are often faded.

Surface Treatment and Texture. This category denotes treatments on sherd surfaces, including polish, slips, and textured treatments. Manipulation refers to surface treatments resulting from the presence or type of coiled construction, and subsequent surface textured decoration and polishing. Slips are defined here as the intentional application of a distinctive clay, pigment, or organic deposit over the entire vessel surface. Such applications may be used to achieve black, white, or red surface colors, not obtainable using paste clays or methods normally employed. Surface treatment categories

Table 9. Ceramic Type by Excavation Unit

Type	Modern Ground Surface		Surface Strip		Cultural Layer	
	#	%	#	%	#	%
Kwahe'e Black-on-white	1	8.3				
Santa Fe Black-on-white	1	8.3			1	3.3

Galisteo Black-on-white			4	7.1	1	3.3
Unpainted Galisteo paste			13	23.2	2	6.7
Plain rim			1	1.8	1	3.3
Plain body	5	41.7	1	1.8	6	20
Indeterminate corrugated			1	1.8		
Plain corrugated			1	1.8		
Low relief corrugated	5	41.7	35	62.5	19	63.3
Total	12		56		30	

Type	Extramural Feature 2		General Structural Fill		Testing		Total	
	#	%	#	%	#	%	#	%
Kwahe'e Black-on-white					1	4.3	2	1.0
Santa Fe Black-on-white					2	8.7	4	2.0
Galisteo Black-on-white			1	1.4			6	3.0
Unpainted Galisteo paste			8	11.1	8	34.8	31	15.7
Plain rim	1	25					3	1.5
Plain body	3	75	8	11.1	2		25	12.7
Indeterminate corrugated			13	18.1			14	7.1
Plain corrugated							1	.5
Low relief corrugated			42	58.3	10	45.3	111	56.3
Total	4		72		23		197	

Table 10. Distribution of Temper by Ware

Temper	White Ware		Gray Ware		Total	
	#	%	#	%	#	%
Sand	5	11.6	4	2.6	9	4.5
Granite			139	90.3	139	70.6
Sherd	5	11.6			5	2.5
Sherd and sand	12	27.9			12	6.1
Tuff	1	2.3			1	.5
Fine tuff and sand	2	4.7			2	1.0
Fine sand and silt with mica	1	2.3			1	.5
Anthill sand			11	7.1	11	5.6
Shale and sand	2	4.7			2	1.0
Fine sand	1	2.3			1	.5
Shale and sherd	14	32.6			14	7.1
Total	43		154		197	

identified during the present study include plain unpolished, plain polished, slipped white, indented corrugated, plain corrugated, and smeared corrugated.

Vessel Form. Observations relating to sherd shape and surface manipulations provide clues concerning the vessels forms from which they derived. Sherds whose form could not be determined, usually because of a missing surface, were assigned to an indeterminate category. Body sherds exhibiting polish or painted decoration on the interior surface, indicating they probably originated

from bowls, were classified as bowl body. Most of the sherds examined during the present study were unpolished body sherds, therefore the precise vessel form could not be determined. While all unpolished gray body sherds were assigned to a jar body category, some of these could have derived from bowls. Polished body sherds were assigned to this category only if they exhibited evidence of painting or polishing on the exterior surface only. Jar neck includes nonrim jar sherds with curvatures indicating that they were derived from the neck of a jar. Most sherds assigned to this category were probably derived from cooking or storage jars. A variety of jar forms were recognized based on rim diameter and shape of these sherds. Jar rim (cooking/storage jars) refers to jars with relatively wide rim diameters. Such sherds appear to have been utilized for cooking or storage. Wide mouth jar sherds are distinguished from other jar rim forms by wide rim diameters relative to vessel size (Table 11).

Table 11. Distribution of Vessel Form by Ware

Vessel Form	White Ware		Gray Ware		Total	
	#	%	#	%	#	%
Indeterminate	1	2.3	5	3.2	6	3.0
Bowl body	18	41.9			18	9.1
Jar neck	1	2.3	21	13.6	22	11.2
Jar rim			15	9.7	15	7.6
Jar body	23	53.5	113	73.4	136	69.1
Total	43		154		197	

Refired Color. Refired paste color was recorded for a subsample of sherds as well as clay samples from local sources (Table 12). Refiring analysis involved the firing of small sherd clips and clay tiles to standardized oxidation atmospheres and a temperature of 950 degrees Centigrade. Refiring samples in similar conditions controls the effects of both previous firings and organic material on paste color (Shepard 1963). This provides for a very rough matching of clay sources based on the influence of mineral content, particularly iron, on refired color. Colors of different refired sherd and clay samples were recorded using Munsell color categories. Unfortunately, the nature of color characterizations are fairly broad so that sherds firing to a particular color could originate from a number of sources. This technique may, however, help identify clays not available in local sources, and thus assist in the recognition of nonlocal ceramics.

Typological Categories

Each sherd was also assigned to a ceramic type category. Type categories reflect combinations of traits of known spatial, functional, or temporal significance. The assignment of sherds to typological categories involved first the determination of associated tradition, the ware group, and finally

Table 12. Hue Color Category of Refired Samples

Hue	White Ware		Gray Ware		Total	
	#	%	#	%	#	%
2.5YR	3	33.3	15	88.3	18	69.2
5YR	4	44.4	2	11.7	6	23.1
7.5YR	1	1.1			1	3.8

10YR	1	1.1			1	3.8
Total	9		17		26	

temporally sensitive ceramic types. All sherds examined during the present study were assigned to five Northern Rio Grande gray ware and four Tewa or Rio Grande white ware type categories.

Gray Ware Categories

Several characteristics are used to distinguish gray utility wares from decorated white ware types known to have been produced in the Northern Rio Grande region and other Anasazi regions (Wilson and Blinman 1995). Gray wares are almost always unpolished on both surfaces, and temper particles are often visible through the surface. The great majority of gray ware sherds exhibiting various textures are derived from cooking or storage jar forms. Exterior surfaces are often dark gray or black resulting from sooting during cooking. Unfortunately, few studies have described utility ware pottery from Northern Rio Grande sites in any detail, so very little is known about temporal or spatial variation in this pottery (Habicht-Mauche 1993).

Utility ware sherds from LA 115266 exhibit ranges of paste and surface characteristics similar to those noted at other Rio Grande Coalition phase sites (Habicht-Mauche 1993; Lang 1989). Paste cross sections are dark gray to black in color. Sherds consistently fire red in an oxidizing atmosphere, reflecting the use of high iron, and a reducing firing atmosphere. Pastes tend to be soft, and sherds crumble very easily. Surface and paste texture is silty. Surface color varies from gray to brown and tan. The great majority of gray ware sherds examined during the present study contain granite temper in a micaceous paste. The earliest Rio Grande "micaceous" types are described by Warren (1981) as reflecting the use of local mica-containing cobbles as temper rather than a micaceous clay. Gray ware pottery with this paste are widely scattered through much of the Northern Rio Grande, and is subsumed by Habicht-Mauche (1993) under a Santa Fe series of Rio Grande Gray Ware. Similar gray wares with mica and granite temper dominate assemblages in much of the Northern Rio Grande region including Coalition phase sites in the general area where LA 115266 is located (Cordell 1978; Habicht-Mauche 1993; Kidder and Shepard 1932; Lang 1992; Mera 1935). While gray wares with micaceous pastes were produced in the Rio Grande region well into the historic period, there appears to have been a shift to highly micaceous clays or slips during the Classic period (Warren 1981).

A very small number of utility ware sherds exhibit lighter colored pastes often in a paste without mica. Temper in examples exhibiting these pastes include sand or anthill sand. These sherds probably reflect a separate manufacturing area that may be to the west, on or near the Pajaritio Plateau.

The great majority of the sherds from LA 115266 exhibit combinations of pastes and surface manipulation similar to pottery previously classified as Rio Grande corrugated or Tesuque corrugated (Habicht-Mauche 1993). Rio Grande corrugated is sometimes used to refer to pottery displaying distinct unobliterated corrugations, while Tesuque Gray refers to the wide range of low-relief and obliterated coil surface treatments that dominated Rio Grande Gray Ware pottery produced during the Coalition period (Habicht-Mauche 1993). This is by far the dominant category recorded at most Coalition phase sites in the region, and at Arroyo Hondo included over 99 percent of all the gray ware pottery (Habicht-Mauche 1993). During the present study, gray ware pottery was divided into descriptive categories based on the nature of exterior surface texture. These categories document similar, but more specific ranges of variations on exterior texture than the divisions implied by Tesuque Gray and Rio Grande corrugated. Basic utility ware categories utilized during the present study were plain gray, low relief (Tesuque) corrugated, indented corrugated, and plain corrugated.

Plain gray refers to gray ware sherds that have been smoothed on both surfaces and exhibit no remnants of exterior coil junctures. Similar pottery seems to have been on occasions subsumed under Tesuque Gray (Habicht-Mauche 1993). Such assignments are particularly common in Coalition phase assemblages where plain gray ware sherds appear to be derived from the obliterated portions of Tesuque Gray vessels. Other studies have placed similar plain ware sherds into a distinct plain surface gray ware category (McNutt 1969; Traylor and Schafe 1982). Plain body and plain rim sherds were assigned to two distinct groups in order to distinguish plain sherds not derived from the lower portion of corrugated vessels. Plain gray ware sherds from LA 115266 are represented by 2 plain rim and 22 plain body sherds. All but five of these sherds contain micaceous granite similar to that dominating most of the other gray wares at this site. These other sherds include one with sand temper and four with anthill sand.

Low relief (Tesuque) corrugated refers to gray ware sherds exhibiting low relief indentations and distinct junctures between coils. This includes sherds that have been assigned by others to Tesuque Utility (Habicht-Mauche 1993). While these sherds were initially assigned to a smeared corrugated category, a review indicates that despite the low relief of these coils, they exhibited distinct juncture between coils. Such junctures are often absent in large numbers of sherd assemblages dating to the late Coalition or early Classic period, and reflect a shift to an inside coiling technique resulting in the obliteration of coil junctures on the exterior surface (Blinman and Price 1998). The low relief category as used here refers to coil junctures with the coil lines visible on the surface, but where coils protrude very little. This category tends to be distinct from forms with more protruding corrugations common in the earlier Developmental phase components as well as the smeared corrugated dominating some late Coalition and early Classic phase assemblages. The use of this three-category system may provide the opportunity to monitor temporal changes that may not be detected in the Tesuque Gray category alone (Habicht-Mauche 1993; Mera 1935). For example, the use of this category as opposed to smeared corrugated indicates a strong difference in the degree of surface obliteration between corrugated and plain sherds, as intermediate smeared corrugated forms are absent. Low relief corrugated pottery may dominate assemblages dating to the thirteenth century. More data, however, are required before it can be determined whether the proposed change in gray ware terminology is either valid or useful. A total of 111 sherds were assigned to the low relief corrugated category. All but ten of these sherds are tempered with granite and mica. Other temper is represented by three examples with sand and seven examples with anthill sand.

Indented corrugated refers to gray ware sherds with distinct indented corrugated exterior treatments. Such treatments are represented by fine conspicuous coils with regular shaped indentations that usually occur over the entire vessel surface. This includes pottery that would probably be placed into a Rio Grande Corrugated category by other analysts (Habicht-Mauche 1992). Such treatments dominate corrugated sherds dating to the Late Developmental phase of the Rio Grande sequence (McNutt 1969). Sherds exhibiting similar treatments but without regular space indentations were assigned to a plain corrugated category. A total of 14 sherds were classified as plain corrugated. All of these sherds contained granite and mica temper.

Rio Grande White Ware Types

White ware sherds from LA 115266 exhibit pastes, styles, and pigments occurring in Rio Grande types dating to the Late Developmental and Coalition phase. The white wares from this site were assigned to typological categories based on the presence and type of paint and characteristics of temper and pastes. Such distinctions resulted in the recognition of five different white ware types or varieties. Kwahe'e Black-on-white is distinguished from the later Santa Fe Black-on-white or Galisteo Black-on-white types by the presence of mineral rather than organic paint. Santa Fe Black-on-white and Galisteo Black-on-white both exhibit organic paint and are distinguished by paste,

temper, surface manipulation, and stylistic characteristics that have both temporal and spatial connotations. Distinctions utilized during the present study were based solely on differences in paste and temper. Such differences reflect basic geological differences in clays available and utilized in different areas of the Northern Rio Grande region (Habicht-Mauche 1993). Santa Fe Black-on-white pottery commonly exhibits fine high iron alluvial or volcanic pastes and tempers available and utilized in the Northern Rio Grande region. Galisteo Black-on-white pottery reflects the utilization of low iron clays and added sherd or sand temper in areas of the Galisteo Basin. While both types overlap temporally, Galisteo Black-on-white is often described as lasting later than Santa Fe Black-on-white. This may partly result from the later occupation of Coalition phase sites dominated by white wares in the Galisteo Basin relative to other areas, such as the Pajarito Plateau.

Two sherds were assigned to Kwahe'e Black-on-white. They were derived from bowls, had fairly light colored pastes, and were tempered with shale and sherd. The combination of paste, temper, and surface treatment are similar to and may foreshadow later developments noted for organic painted pottery. This Kwahe'e Black-on-white appears to reflect earlier utilization of low iron geological clays in this area, which is also a distinctive trait of Galisteo Black-on-white.

During the present study organic-painted sherds of Galisteo Black-on-white were distinguished from Santa Fe Black-on-white by the presence of a light paste and sand and sherd rather than fine tuff temper. Most of these sherds were unslipped and did not generally exhibit white slips or heavy polish or other distinctive Mesa Verde-like traits sometimes described for Galisteo Black-on-white (Lambert 1954; Lang 1982; Stubbs 1953). In contrast to most descriptions of Galisteo Black-on-white, sherds placed into this category tended to be very thin. Pastes are light gray to white, and fired from white, pink, to yellow-red colors in an oxidizing atmosphere. Surfaces were light in color, moderately polished, and usually unslipped. During this study, there was a tendency to place sherds exhibiting lighter pastes or temper rather than fine tuff into Galisteo Black-on-white, and it is likely that some of the sherds assigned here as Galisteo Black-on-white may be similar to sherds placed into Santa Fe Black-on-white by others. Thus, organic-painted white wares in the Eldorado area may reflect the initial utilization of cretaceous clay sources similar to those commonly utilized later in the Galisteo Basin in an early Santa Fe Black-on-white variety. Forms noted in Galisteo Black-on-white sherds include jars and bowls. A range of temper types were noted in the Galisteo Black-on-white sherds identified including sand, sherd, sherd and sand, shale and sand, fine sand, and shale and sherd. A total of six sherds exhibiting this paste and decorations such as thin lines in a black organic paint were classified as Galisteo Black-on-white. These included sherds exhibiting solid and hatched designs. A total of 31 unpainted white ware sherds exhibiting a similar paste were assigned to an unpainted Galisteo paste category, which could also include some unpainted Kwahe'e sherds.

Santa Fe Black-on-white appears to have developed out of the earlier mineral-painted Kwahe'e Black-on-white. Vessel walls are relatively thin and even in thickness. Pastes are often dense, hard, well fired, and vitreous. Pastes range from light gray to blue-gray in color, but may be brown or reddish when misfired. Decorated surfaces are usually polished and covered with a thin, streaky white slip. Undecorated surfaces are often rough and unslipped. Tempering materials include fine sand or finely crushed volcanic rock temper. Sherds fired to yellow-red colors in an oxidizing atmosphere. All four sherds assigned to Santa Fe Black-on-white based on temper during the present study exhibited indistinct painted decorations in black organic paint. Temper types represented include fine tuff and sand, tuff, and fine sand with mica. Vessel forms include bowls and jar.

Examination of Ceramic Trends

Ceramic type and attribute distributions may be used to examine a wide range of issues relating to the time and nature of the occupation of LA 115266. A total of 23 sherds were recovered during the testing phase, and 174 sherds were found during the recovery phase. Together, these sherds probably

represent a minimum of 40 vessels. Proveniences from which ceramics were recovered include the modern ground surface (yielding 12 sherds), surface strip (56 sherds), cultural layer (30 sherds), extramural feature (4 sherds), and Pit Structure 1 fill (72 sherds).

Ceramic Dating

Distributions of pottery types definitely indicate an occupation sometime during the Coalition phase (see Table 9). Most of the white ware sherds are derived from organic-painted types dating to the Coalition phase. While Galisteo Black-on-white sherds clearly outnumber Santa Fe Black-on-white sherds, much of this dominance may be related to a large number of sherds derived from a single vessel. Santa Fe Black-on-white may have been first produced by the late A.D. 1100s and was definitely produced by A.D. 1200 (Lang 1997). It is the most common white ware type at sites in the Santa Fe area during the entire thirteenth century and into the mid-fourteenth century. Santa Fe Black-on-white is often characterized as having been replaced by Wiyo Black-on-white or Galisteo Black-on-white sometime in the fourteenth century.

While in areas south of Santa Fe, Galisteo Black-on-white is commonly described as having replaced Santa Fe Black-on-white at about A.D. 1300, the dating of Galisteo Black-on-white may largely depend on how this pottery is defined. For example, while sherds exhibiting white paste and sherd and/or sand temper were assigned to Galisteo Black-on-white during the present study, some of these appear to be similar to sherds classified as Santa Fe Black-on-white from the nearby site of Dos Griegos (Lang 1992). If Galisteo Black-on-white is defined by Mesa Verde-like attributes, including high polishing, thick white slips, and square ticked rims, a beginning date of 1300 may be appropriate (Habicht-Mauche 1993). Examinations of pottery from LA 3333, however, indicate that if Galisteo Black-on-white is defined by white paste and sherd and/or sand temper, it may date during the early A.D. 1200s. An early thirteenth-century date for Galisteo Black-on-white, as defined by clay and temper resources, probably reflects the movement of groups into areas southeast of Santa Fe where white firing clays (to which temper had to be added) were available. The A.D. 1300 beginning date for Galisteo Black-on-white probably reflects that most of the larger and better-known sites in the Galisteo Basin and adjacent areas were not occupied until the A.D. 1300s. Still, there is some evidence of earlier occupations at smaller sites in the Galisteo Basin with pottery exhibiting styles and forms characteristic of Santa Fe Black-on-white, but the light paste and sherd temper of Galisteo Black-on-white. The Galisteo Black-on-white sherds from LA 115266 seem to reflect the earlier Santa Fe Black-on-white variety, and it is likely that similar sherds from nearby sites have been assigned to Santa Fe Black-on-white.

Kwahe'e Black-on-white is the dominant white ware type at sites occupied between A.D. 1050 and 1200. It occurs in lower frequencies along with organic-painted Coalition phase sites between A.D. 1200 and 1250 (McNutt 1969). The dominance of lightly corrugated sherds at LA 115266 is also consistent with an early Coalition phase assemblage.

If the pottery classified as Kwahe'e Black-on-white is contemporaneous with that classified as Galisteo Black-on-white, Santa Fe Black-on-white, and smeared corrugated, an occupation sometime during the early thirteenth century may be indicated (Allen 1973). This date is consistent with tree-ring dates that were obtained by Stallings from the nearby site of Pueblo Alamo (Allen 1973). Ceramic data from the Pueblo Alamo site are poorly reported. So, as part of the present study, sherds from selected bags recovered during the excavation of this site were examined. These indicated that Santa Fe Black-on-white outnumbered Galisteo Black-on-white at least 3 to 1. Surface and paste characteristics of the Santa Fe Black-on-white sherds from Pueblo Alamo appeared to be very similar, while those noted for Galisteo Black-on-white sherds appeared to be much more variable and included Santa Fe Black-on-white pottery with white paste and sherd temper as well as the thick forms more characteristic of some descriptions of this type. A wide range of corrugated forms was

also noted at Pueblo Alamo, although the majority of the sherds examined exhibited low relief textures similar to that dominating utility wares from LA 115266.

The assemblages noted at LA 115266 are also very similar to those noted at LA 3333, a site in the Galisteo Basin recently excavated by the Museum of New Mexico, which also yielded dates in the early 1200s. Examination of pottery from this site also indicates the occurrence of early forms of Galisteo Black-on-white along with Santa Fe Black-on-white at sites dating to the early thirteenth century.

Thus, it appears that LA 115266 dates to some time during the thirteenth century and possibly during the early half of this century. This occupation appears to be also contemporaneous with much of the initial occupation of Pueblo Alamo, and it is likely that individuals at this site interacted with the nearby village of Pueblo Alamo. It is also likely that these occupations may reflect the movement of groups from areas to the northeast such as the Tewa Basin during the early Coalition phase. Such occupations may also be related to the better known and later occupations in the Pecos Valley and Galisteo Basin.

Pottery Resources and Production

Characteristics of the pottery examined during the present study may also provide clues concerning the nature of pottery production and exchange. Given the sample size, a fairly wide range of temper types was noted (see Table 10), although temper and paste characteristics indicate that all the sherds examined appear to represent Northern Rio Grande types. Examination of pastes and temper indicate that most of these sherds could have been produced locally, although some originated in other areas of the Northern Rio Grande.

In order to identify pottery that could have been produced locally, clays were collected from nearby sources. Outcrops immediately surrounding LA 115266 represent metamorphic bedrock covered by a sandy soil horizon. The nearest good quality pottery clay sources appear to be associated with thick shale outcrops in the mesas to the east. Geological maps indicate these outcrops were deposited during the Triassic age, and appear to be mainly represented by outcrops of the Chinle Formation. This formation is represented by thick, variable-colored shale members (Baars 1972). The Chinle Formation is best known by extensive and spectacularly colored formations in areas of Arizona and Utah such as the Painted Desert, Petrified Forest, Grand Canyon, and Canyonlands National Park. Exposures west of Santa Fe are located in the easternmost area of known Chinle exposures. Such exposures are rarely described although they are noted in geological maps of this area. Examinations of high exposures just east of Eldorado indicated interdispersed shale beds with the broad range of red, purple, gray, green, yellow, and cold colors for which this formation is famous. A total of six clay samples from beds of various colors were collected (see Appendix 2). All of these samples represent soft weathered silt with a waxy appearance. All samples collected could be easily ground resulting in high quality pottery clay. Most of these clays fired to red colors, although one sample fired to a pink color. The great majority of utility wares fired to reddish colors, some of which match known clay sources. The silty or waxy texture noted in many gray ware sherds also matched that noted in Chinle clays. The range of refired colors noted in clay collected from the Chinle Formation is greater than that noted in the refired sherds. Most of the refired colors noted in the sherds, however, were noted in Chinle clay samples. Thus, it is possible that specific sources within the Chinle Formation may have been utilized for pottery manufacture.

In addition, washes scattered throughout this area contain abundant granite cobbles, which could have been utilized in the local utility ware. Fine sands found in these washes could have also been the source of material noted in some of the Galisteo Black-on-white. The fine tuff noted in Santa Fe Black-on-white sherds was not collected during the present study, although it is probable that such

sources are represented in volcanic deposits in close proximity. It is also likely that gray ware sherds containing temper assigned to the anthill sand category were not locally produced, but reflect material produced in areas of the Pajarito Plateau to the northwest.

Vessel Form and Use. The recovery of ceramics at a particular archaeological context ultimately reflects the use and breakage of vessels used for specific activities. Vessel function is reflected by ceramic ware groups and vessel form.

Distributions of sherds assigned to various ware groups and vessel forms were examined (see Table 11). These examinations indicate that 78.2 percent of this pottery represents utility ware jar forms, while the remaining 22.8 percent of sherds represents a mixture of white ware bowl and jar forms.

Such distributions indicate an emphasis on cooking activities and are similar to frequencies noted at contemporaneous sites in this region. Habicht-Mauche (1993) estimated that corrugated sherds outnumber black-on-white sherds at Arroyo Hondo by 6.5 to 1. At Leaf Water, a Coalition phase site in the Chama Valley, corrugated wares made up about two-thirds of pottery (Wendorf 1953). At Dos Griegos, about 90 percent of the sherds represent corrugated types (Lang 1992). Utility ware makes up about 85 percent of the pottery at the Coalition phase occupation of a site near Pojoaque. Thus, observations relating to the dominance of gray utility wares over white wares are similar to those noted at contemporaneous sites in this area, and appear to indicate the importance of utility ware jars in cooking or storage activities.

RESEARCH QUESTIONS

Test excavation of LA 115266 revealed a multicomponent artifact scatter with a deflated thermal feature and a burned surface thought to represent a jacal field structure dating to the early A.D. 1200s. No further investigation of the unknown prehistoric thermal feature was proposed. The Coalition period component was expected to have strong potential for addressing problems of chronology and settlement of ancestral Pueblo populations. The structure encountered during the testing program turned out not to be a jacal surface structure as initially expected, but instead was a pit structure. Five extramural features associated with the prehistoric occupation were also uncovered. An unknown historic component in the form of a stone-ringed hearth characterizes the final use of the site area. No further discussion of this feature is presented in this section of the report. Although the pit structure was an unexpected discovery, the basic research design is essentially unaltered. Chronology and settlement interpretations are presented in this section.

Chronology

The initial research problem as outlined in the data recovery plan focused on chronology. Was LA 115266 occupied during the early part of the thirteenth century? The testing program proposed an A.D. 1200 to 1250 occupation based on the co-occurrence of Kwahe'e Black-on-white and Santa Fe Black-on-white pottery. However, the proposed early Coalition occupation was based on minimal ceramic evidence. Obtaining additional absolute and relative dates to substantiate the proposed early Coalition period occupation was the primary focus of the investigation.

The simple pit structure layout and nondescript extramural features provide minimal temporal information. Unfortunately, dating the site remains a ceramic problem as no absolute dating samples were recovered during the excavation program. Oxidation was nonexistent for archeomagnetic samples. No prehistoric extramural thermal features were discovered and the informal hearth on the pit structure floor was of insufficient intensity and quality for an archeomagnetic sample. The pit structure had been lightly burned, but only occasional small fragments of oxidized adobe from the roof evidenced the burning. The walls and floor exhibited no oxidation. No wood was preserved from the roof or extramural postholes for dendrochronology samples. Charcoal was contaminated by recent burns on the site, a historic period hearth, shallow fill, and intensive rodent mixing. Radiocarbon dating was low priority because of the contaminated and mixed charcoal. Charcoal from the informal hearth on the pit structure floor was collected as a sample, but was not submitted because of mixing and the old wood problem. Potential error factors for sage as a fuel wood (as high as 300 years) were much greater than the at least 50-year resolution required to address the proposed A.D. 1200 to 1250 occupation.

The ceramic assemblage embodies the best evidence for dating the site. Interpretations are mainly constrained by small sherd sizes. The largest sherds were about the size of a quarter and the bulk of the sherds were smaller. Broadly speaking, the assemblage exemplifies a Coalition period (A.D. 1200-1325) occupation. This is based on the preponderance of organic-painted pottery and the high frequencies of associated low relief gray ware. Some 98 sherds were recovered from surface, surface strip, and cultural layer contexts that are attributed to generalized occupational litter. Another 72 sherds were from the pit structure fill that are viewed as general artifact dispersal and light refuse accumulation post-dating the pit structure abandonment. Sherds from this context should represent the latest artifacts on the site, but no appreciable temporal differences were recognized between the pit structure and the surrounding general occupational fill. The site elements and ceramic assemblage

are attributed to the general Coalition phase occupation, but finer temporal resolution within the multiseason occupation was not obvious.

The question becomes more complicated when focusing on an early versus late Coalition affiliation. Post (1999:29) proposed an occupation during the early part of the thirteenth century and several ceramic attributes support this contention. Galisteo Black-on-white commonly replaces Santa Fe Black-on-white around A.D. 1300. Santa Fe Black-on-white appears to outnumber Galisteo Black-on-white at least 3 to 1 at nearby Pueblo Alamo. While Galisteo Black-on-white outnumbers Santa Fe Black-on-white at LA 115266, the numbers may be related to sherds derived from a single vessel (see ceramic section). Most importantly however, the Galisteo Black-on-white sherds from LA 115266 seem to reflect the earlier Santa Fe Black-on-white form rather than the classic Mesa Verde-like attributes including high polishing, thick white slips, and square ticked rims. Sherds designated as Galisteo Black-on-white at LA 115266 would often be identified as Santa Fe Black-on-white at surrounding sites. The assemblage is very similar to LA 3333, an early Coalition site in the Galisteo Basin with both early forms of Galisteo Black-on-white and Santa Fe Black-on-white (see ceramic section). The few Kwahe'e Black-on-white sherds overlap with, and support the early occupation, whereas no associated later types such as Wiyo Black-on-white or glaze decorated sherds were recovered. Sherd sizes were too small to address temporal trends in design elements.

Gray ware surface treatment is dominated by low relief corrugated. Blinman and Price (1988:4) observed predominantly exterior coiled and unsmearred indented corrugated pottery in the LA 3333 assemblage, which dated to the first quarter of the thirteenth century. The bulk of the LA 115266 gray ware reflects this same surface treatment, which lends credibility to the early Coalition affiliation. The category is distinct from varieties with more protruding corrugations common in the preceding Developmental phase, as well as the smeared corrugated that dominated late Coalition and early Classic phase assemblages (see ceramic section). The majority of the gray ware sherds examined from Pueblo Alamo had low relief textures similar to the LA 115266 assemblage.

In conclusion, the LA 115266 ceramic assemblage depicts a thirteenth-century date with various ceramic attributes supporting an occupation during the initial half of this century. The slab metate from the site supports a general Coalition phase occupation, and two undifferentiated projectile point fragments provide little temporal information. The occupation is contemporaneous with the initial occupation of Pueblo Alamo, but may not extend to the founding of Chamisa Locita.

Settlement

The second research question focused on the nature of the settlement. Was LA 115266 occupied for only one or two seasons, and does it therefore represent a temporally discrete slice of early Coalition period settlement or farming expansion? Although the pit structure was an unexpected discovery, the basic research design is essentially unaltered. The pit structure (rather than a jacal surface structure as originally defined) most likely functioned as a seasonally occupied farming shelter. Site elements and artifact assemblages shed some light on the intensity and duration of the occupation.

The pit structure discovered during excavation introduces an interesting architectural twist into the nature of the settlement. The pit structure construction required a greater energy investment than a simple jacal surface structure. We found the natural alluvium compact and not easy to dig even with metal tools. The pit structure was the central architectural element around which the site was organized. Pit structures are a common pueblo architectural element. The insulation value associated with pit structure architecture commonly suggests full season occupation. However, the small simple

lay out and most importantly the absence of a formal hearth indicates that this was not the case at LA 115266. The informal hearth on the pit structure floor characterizes a single, low-intensity burning episode. The need for winter heat and space for sheltered food preparation was not required. The main structure therefore was designed for seasonal, warm weather use. Burned adobe fragments from the roof and light refuse in the fill indicates that this was a finished structure and not merely an example of incomplete construction. The probable ramada also argues for warm weather occupation and the need for shade.

Of interest is the occurrence of a mealing station as the primary feature on the pit structure floor. In addition to shelter, the insulative nature of the pit structure would have provided a cool environment for this demanding activity. The mealing station indicates the presence of a woman, and a mixed-gendered household opposed to just male farmers tending fields. At least one hunting-age male is suggested by the few projectile points.

The site is seemingly structured to support a mixed household during the growing season. The duration of this seasonal pattern is the question. Basically, the small structure size and restricted site area supports short-term site use. Occupation may have extended over several months and was intense enough to develop a shallow layer of culturally stained fill across the site. However, occupation intensity fell short of the development of formal midden deposits. Light refuse was informally scattered around the site without a noticeable concern for cluttered living or activity space. The possible storage facility suggests that the household was concerned with self-sufficiency for extended periods, but the contemporary village was only a 20 minute walk away. It is interesting that the proposed storage facility was located outside of the pit structure and away from the mealing station, considering corn was conceivably the item stored in the feature.

The small artifact assemblage of just over 200 artifacts is not supportive of a complicated and lengthy occupation. This is especially true of the small chipped stone and faunal assemblages. The presence of young animals in the faunal assemblage again advances seasonal use during the summer growing season. Considering a household of at least two persons, the small chipped stone and faunal assemblages denote short occupations. In contrast, the ceramic assemblage may be composed of as many as 40 vessels denoting a full complement of storage, cooking, and serving activities. The ceramic assemblage depicts an occupation that may extend over some eight seasons, based on an estimated breakage rate of five vessels per season (Kohler and Blinman 1985). This projected occupation length corresponds well with the use-life of a pit structure. Pit structures have an average lifespan of about 15 years, with some 10 years elapsing between remodeling and repair (Schlanger 1988:783). The pit structure at LA 115266 showed no indications of remodeling. The ramada, which probably had a similar lifespan, was replaced, and may have outlived the pit structure accounting for the continued low-level accumulation of artifacts after the pit structure abandonment.

In summary, I argue that LA 115266 was occupied seasonally during the growing season by a mixed-gender household consisting of at least two individuals. The limited artifact assemblage suggests that occupation intensity was not continuous during the seasonal occupation. The household almost certainly benefitted from the near proximity of the large village. The duration of the occupation was at least eight to ten seasons based on the estimated breakage rates for the ceramic vessels and the use-life of the pit structure and probable ramada.

Discussion

The local Coalition period settlement pattern centers around the two large adobe villages of Pueblo Alamo and Chamisa Locita. The settlements were sustained by the presence of perennial springs, arable land along the floodplains of Cañada de los Alamos and Gallina arroyos, and a wide range of resources made readily available by the foothill-piedmont contact zone. Water availability followed by arable land were the two critical factors influencing prehistoric Pueblo settlement. Using these criteria, Dickson (1979:80-82) rated the Cañada de los Alamos as secondary in terms of suitability for human use. Primary districts characterized by rainfall and intermittent runoff, perennial springs, perennial stream flow, and more than 100 acres of arable land included the Rio Grande floodplain, the Santa Fe River, and the upper Galisteo Arroyo. Secondary districts with rainfall and intermittent runoff, perennial springs, and 50 to 100 acres of arable land included Arroyo Hondo and Cañada de los Alamos. Tertiary districts with rainfall and intermittent runoff and 10 to 50 acres of arable land included the middle Arroyo Hondo drainage, and by extension the middle Cañada de los Alamos and Gallina Arroyo. Although similar to the Arroyo Hondo context, the Cañada de los Alamos lands were rated at a slightly lower quality (Dickson 1979:81). In fact, the Cañada de los Alamos would rate last in comparison with the Rio Grande, Santa Fe River, Galisteo Arroyo, and Arroyo Hondo.

Coalition period settlements were spaced at roughly 5-mile intervals between Pindi Pueblo on the Santa Fe River and Pueblo Alamo (Dickson 1979:68). This settlement pattern seemed to represent the optimum balance between population and carrying capacity given the technical level of the times. The presence of perennial springs and the perpetual renewal of soil nutrients through periodic flooding made Arroyo Hondo one of the best agricultural spots south of the Santa Fe River. The Arroyo Hondo spring still flows today. In contrast, Pueblo Alamo and Chamisa Locita are positioned to take advantage of two smaller arroyos emanating from the foothills. Springs in the vicinity of Pueblo Alamo and Chamisa Locita are either currently dry or have greatly reduced flow rates. Dickson (1979:82) considered Cañada Ancha a smaller east-west running arroyo half way between Arroyo Hondo and Pueblo Alamo as the boundary separating the sustaining or use areas of these settlements.

The onset of Coalition period settlement around A.D. 1200 saw both the colonization of secondary districts such as the Cañada de los Alamos and the aggregation of population into larger villages. Only three small late Developmental period artifact scatters portray prior local Developmental components. The Pueblo Alamo and Chamisa Locita sustaining area is characterized by a settlement pattern consisting of large adobe pueblos, pithouse hamlets, fieldhouses, and artifact scatters. The larger pueblos range from 100 to 300 rooms, pithouse hamlets have 1 to 3 structures and possible surface jacal structures, fieldhouses have masonry, jacal, and pithouse architecture, and simple artifact scatters may mask more complex occupations. The sites are associated with farming along the Cañada de los Alamos and Gallina floodplains, but the relationship within the site hierarchy is unclear.

Of specific interest are the recently recorded pithouse sites and how they relate to the larger pueblos. Three sites consisting of as many as seven pit structures are clustered less than .5 km south of LA 115266 (Marshall 1993, 1998). The sites have Coalition period ceramic assemblages and the largest site (LA 100778) has early Santa Fe Black-on-white and mineral-painted sherds suggesting early Coalition affiliation. The ceramic assemblages from these sites have common characteristics with those from LA 115266. The occupations could easily overlap. We found pithouse visibility challenging during our visit to the sites. However, midden areas were well-developed, exemplifying definite residential occupations. The relationship of these residential pithouse sites with the larger villages and the nearby fieldhouses is undetermined. The sites could represent initial colonization of

the drainages prior to consolidation into the larger villages, or contemporaneous outlying residential sites. The well-developed trash accumulations suggest self-sufficient full-time occupations contrasting with the seasonal nature of the LA 115266 fieldhouse. The LA 115266 household spent time away from the fieldhouse at either the larger villages or the nearby pithouse hamlets. The fieldhouse nature of LA 115266 seems superfluous to the nearby pithouse hamlets unless the site elements represent peripheral sprawl around the core residential structures. A better fit seems to be that of a remote fieldhouse occupied after abandonment of the hamlets and nucleation of the population into the larger villages. This settlement problem can only be clarified by future research on the hamlet sites.

Local survey suggests that fieldhouses are located about every .5 km along the Cañada de los Alamos between Pueblo Alamo and the vicinity of LA 115266. Four fieldhouses are situated to farm the Cañada de los Alamos floodplain, one is positioned along the Gallina Arroyo, and another is positioned along a small east tributary receiving runoff from the eastern foothills. These are generally more substantial structures visible as masonry or adobe mounds. Additional seasonal sites appearing as meager artifact scatters have probably not been recognized. LA 115266 and LA 75680, the two excavated fieldhouses in the area, both were visible on the surface as small artifact scatters.

Preucel (1988) found that fieldhouses were first used on a large scale during the late Coalition (A.D.1275-1325) on the Pajarito Plateau west of the project area. Coinciding with the rise of large villages, the fieldhouses minimized the costs of transportation to and from the fields and were a means of laying claim to agricultural land. The founding of fieldhouses was a symbol of ownership as farming communities increased. Kohler (1992) expands on the concept of land ownership and control with the appearance of fieldhouses and villages. Individuals or households may have controlled agricultural lands while in use, but the lands remained communal property and could potentially be reallocated to other members of the community. Fieldhouses were an attempt to limit access to previously unregulated lands in response to increased population and resource scarcity. During Anasazi colonization and ecosystem-development cycles, local population growth typically stops with aggregation associated with fieldhouses, both indications that open land access has been closed to newcomers (Kohler 1992:632). Preucel found that distances between seasonal sites and associated residences increased from .14 km in the early Coalition period to 1.62 km in the late Coalition period.

LA 75680 is located less than .5 km south of Pueblo Alamo and is the nearest excavated fieldhouse to the large village. The site is interpreted as a seasonal fieldhouse dating to the early Coalition period, contemporaneous with both Pueblo Alamo and LA 115266. The site was characterized by remodeled jacal surface architecture indicating multiseasonal use. The site lacked storage features, but a food processing basin and the use of corn cobs for fuel pointed to corn growing as the central emphasis for the occupation (Lang 1992:103). The number of broken vessels (Lang estimates 391) was exceptionally large for the small site considering the close proximity of Pueblo Alamo. Site inhabitants were obviously staying at the site and making their presence visible on the landscape. The artifact assemblage evidenced chipped and ground stone tool manufacture, hide working, corn processing, and some hunting. Compared with LA 115266, the artifact assemblage displays a wider range of activities including evidence of ceramic manufacture. The site had surface rather than subsurface architecture, but again women were an important component of the resident social unit expressed by both corn processing and pottery manufacture.

Jeanette Mobley Tanaka (1997:437-448) presents a scenario where subterranean mealing rooms appearing during the Pueblo II pithouse to pueblo transition may be an expression of female corn-related ritual. At the same time, the kiva was emerging as the center of male ritual. She argues that specialized subterranean mealing rooms represented both ritual and social integration that surrounded the importance of corn in Anasazi society, and the importance of the female role in ritual and social

integration. While I do not believe that the LA 115266 pit structure and mealing station represents a specialized mealing room, Mobley-Tanaka's argument supplies grist for a more provocative level of site interpretation. Instead of merely a secular subterranean shelter with a mealing station implying simple economic food processing, the subterranean structure and mealing station might be charged with additional female ritual authority associated with the traditional importance of corn grinding. This ritual significance coupled with the fieldhouse expression of ownership might have doubly reinforced the household's claim to local land use and control.

In any event, LA 115266 represents an interesting but subtle component of the population dynamics that reached a peak during the Coalition period settlement of the Cañada de los Alamos. The substantial population growth does not seem to stem entirely from prior Developmental populations. Survey shows that preceding sites are infrequent and poorly documented, although they may be under recorded because of their poor visibility. Brown ware and Los Lunas Smudged recorded at the nearby pithouse hamlets hint at early Coalition period populations with a Southwest connection. LA 115266 ceramics document connections with the Pajarito Plateau and northern Tewa Basin, areas that were also experiencing migrant population growth. Ceramics, lithic material types, and burials show that the nucleated village of Pueblo Alamo had Plains relationships (Wiseman 1999). The fact that the large village of Pueblo Alamo was burned shows that local social interaction was not always harmonious. Settlement in the surrounding drainage's of Arroyo Hondo, Pecos, and Galisteo continued into the Classic period. In contrast, the Cañada de los Alamos was abandoned at the close of the Coalition period, apparently from climatic conditions combined with the marginal nature of the resources. Settlements along the drainage are important "fossils" of this important period of population dynamics uncluttered by later Classic period effluence. LA 115266 represents roughly a 10-year slice of early Coalition period fieldhouse experimentation. Similarly, the larger villages of Pueblo Alamo and Chamisa Locita represent pure examples of Coalition period village aggregation.

REFERENCES CITED

- Allen, Joseph W.
1973 *The Pueblo Alamo Project: Archaeological Salvage and the Junction of U.S. 85 and U.S. 285 South of Santa Fe, New Mexico*. Laboratory of Anthropology Notes 86. Museum of New Mexico, Santa Fe.
- Andrefsky, William Jr.
1994 Raw Material Availability and the Organization of Technology. *American Antiquity* 59(1):21-34.
- Baars, Donald L.
1983 *The Colorado Plateau; A Geological History*. University of New Mexico Press, Albuquerque.
- Bamforth, Douglas B.
1991 Technological Organization and Hunter-Gatherer Land Use: A California Example. *American Antiquity* 56(2):216-234.
- Binford, Lewis R.
1977 *For Theory Building in Archaeology*. Academic Press, Inc. London.
- 1979 Organization and Formation Processes: Looking at Curated Technologies. *Journal of Anthropological Research* 35(3):265-283.
- 1980 Willow Smoke and Dogs' Tails: Hunter-Gatherer Settlement Systems and Archaeological Site Formation. *American Antiquity* 45(1):4-20.
- Blinman, Eric, and Carol E. Price
1998 Turning Anasazi Pottery Outside-In: Construction Techniques and Immigration in the Rio Grande Valley. Paper presented at the 63rd Annual Meeting of the Society for American Archaeology.
- Camilli, Eileen
1989 The Occupational History of Sites and the Interpretation of Prehistoric Technological Systems: An Example from Cedar Mesa, Utah. In *Time, Energy, and Stone Tools*, edited by R. Torrance, pp. 17-26. Cambridge University Press, England.
- Cordell, Linda S.
1978 *A Cultural Resources Overview of the Middle Rio Grande Valley, New Mexico*. U.S. Government Printing Office, Washington, D.C.
- Dickson, D. Bruce Jr.
1979 *Prehistoric Pueblo Settlement Patterns: The Arroyo Hondo New Mexico Survey*. Arroyo Hondo Archaeological Series, vol. 2. School of American Research Press, Santa Fe.
- Ebert, James I.
1992 *Distributional Archaeology*. University of New Mexico Press, Albuquerque.
- Folks, James J.
1975 *Soil Survey of the Santa Fe Area, New Mexico*. United States Department of Agriculture, Soil

Conservation Service.

Grant, P. R. Jr.

1997 An Overview of Geologic, Hydrologic, and Legal Constraints at Eldorado Subdivision, Santa Fe County, New Mexico. Ms. on file State Engineer's Office, Santa Fe, New Mexico.

Habicht-Mauche, Judith A.

1993 *The Pottery from Arroyo Hondo Pueblo, New Mexico; Tribalization and Trade in the Northern Rio Grande*. Arroyo Hondo Archaeological Series, vol. 8. School of American Research Press, Santa Fe.

Hannaford, Charles A.

1998 Site form for LA 125568: Spirit Haven Shrine. Site form on file at the Archaeological Records Management Section, Historic Preservation Division, Santa Fe, New Mexico.

Kelley, N. Edmund

1980 *The Contemporary Ecology of Arroyo Hondo New Mexico*. Arroyo Hondo Archaeological Series, vol. 1. School of American Research Press, Santa Fe.

Kelly, Robert L.

1988 The Three Sides of a Biface. *American Antiquity* 53(4):717-734.

1995 *The Foraging Spectrum; Diversity in Hunter-Gatherer Lifeways*. Smithsonian Institution, Washington, D.C.

Kidder, A.V., Anna O. Shepard

1932 *The Pottery of Pecos*, vol. 2, *Glaze, Culinary, and Other Wares*. Papers of Phillip Academy No. 7. New Haven, Connecticut.

Kohler Timothy A.

1992 Field Houses, Villages, and the Tragedy of the Commons in the Early Northern Anasazi Southwest. *American Antiquity* 57(4):617-635.

Kohler Timothy A., and Eric Blinman

1987 Solving Mixture Problems in Archaeology: Analysis of Ceramic Materials for Dating and Demographic Reconstruction. *Journal of Anthropological Archaeology* 6(1):1-28.

Lambert, Majorie

1954 *Paa-ko*. School for America Research Monographs 19. Santa Fe, New Mexico.

Lang, Richard W.

1982 Transformation in White Ware Pottery of the Rio Grande. In *Southwestern Ceramics: A Comparative Review*. edited by Albert Schroeder, pp. 153-200. The Arizona Archaeologist no. 15, Phoenix.

1989 *Limited Excavations at LA 2, the Aqua Fria Schoolhouse Site, Aqua Fria Village, Santa Fe County, New Mexico*. Southwest Report No. 216, Southwest Archaeological Consultants Inc., Santa Fe, New Mexico.

1992 *Archaeological Excavations at Dos Griegos. Upper Canada de Los Alamos, Santa Fe County, New Mexico: Archaic through Pueblo V*. Southwest Report No. 283. Southwest Archaeological Consultants Inc., Santa Fe, New Mexico.

- 1997 Ceramics from Archaeological Sites in the Vicinity of the Jemez Mountains: The Ole Corridor. In *OLE Volume II: Artifacts*, edited by John C. Acklen, pp. 231-276. TRC Mariah Associates Inc., Albuquerque.
- Maker H. J., J. J. Folks, and J.U. Anderson
 1971 *Soil Associations and Land Classification for Irrigation Santa Fe, County*. New Mexico State University Agricultural Experiment Station, Research Report No. 185. Las Cruces, New Mexico.
- Marshall, Michael P.
 1993 *A Cultural Resource Survey of the Los Caballos Estates Lot 4-12, a 253 Acre Tract in the Canada de los Alamos Drainage, Santa Fe County, New Mexico*. Cibola Research Consultants, Report No. 72. Corrales, New Mexico.
- 1998 *A Cultural Resource Survey for the Proposed U.S. 285 Highway Improvement Project, Santa Fe County, New Mexico*. Cibola Research Consultants, Report No. 164. Corrales, New Mexico.
- McNutt, Charles H.
 1969 *Early Puebloan Occupations at Tesuque By-Pass and in the Upper Rio Grande Valley*. Anthropological Paper No.40. Museum of Anthropology, University of Michigan, Ann Arbor.
- Mera, H. P.
 1935 *Ceramic Clues to the Prehistory of North Central New Mexico*. Technical Series Bulletin No. 8. Laboratory of Anthropology, Santa Fe, New Mexico.
- Mobley-Tanaka, Jeannette L.
 1997 Gender and Ritual Space during the Pithouse to Pueblo Transition: Subterranean Mealing Rooms in the North American Southwest. *American Antiquity* 62(3):437-448.
- Moore, James L.
 1994 Chipped Stone Artifact Analysis. In *Studying the Taos Frontier: The Pot Creek Data Recovery Project*, vol. 2: *Discussion and Interpretation*, by J. L. Boyer, J. L. Moore, D. F. Levine, L. Mick-O'Hara, and M. S. Toll, pp. 287-338. Office of Archaeological Studies, Archaeology Notes 68, Museum of New Mexico, Santa Fe.
- n.d. *Historic Occupation of the Glorieta Valley in the Seventeenth and Nineteenth Centuries; Excavations at LA 76438, LA76139 and LA99029*. Office of Archaeological Studies, Archaeology Notes 262. Museum of New Mexico, Santa Fe.
- Nelson, Nels
 1915 Original Field Notes on LA 4 and LA 8 Excavations. On file at the Archaeological Records Management Section, Historic Preservation Division, Santa Fe, New Mexico.
- (OAS) Office of Archaeological Studies
 1994 *Standard Lithic Artifact Analysis: Attributes and Variable Code Lists*. Office of Archaeological Studies, Archaeology Notes 24c. Museum of New Mexico, Santa Fe.
- Phagan, Carl J.
 1993 *The Stone Artifacts from Arroyo Hondo Pueblo*. Arroyo Hondo Archaeological Series 8(2). School of American Research Press, Santa Fe, New Mexico.
- Post, Stephen S.

- 1994 *An Archaeological Survey of a 20 Acre Lot-Split Near Cañada de los Alamos, Santa Fe County, New Mexico.* Stephen S. Post Consulting Archaeologist Report No. 37, Santa Fe.
- 1996 *Las Campanas de Santa Fe, Sunset Golf Course, and Estates , Estates V, and Estates VII Excavations.* Archaeology Notes 1993. Office of Archaeological Studies, Museum of New Mexico, Santa Fe.
- 1998 *Excavations at Rancho Viejo de Santa Fe: Ancient Patterns of Mobility and Land Use.* Office of Archaeological Studies, Archaeology Notes 252. Museum of New Mexico, Santa Fe.
- 1999 *Archaeological Testing Results from LA115266 and LA115268 and Data Recovery Plan for LA 115266, Along US 285 Near Eldorado, Santa Fe County, New Mexico.* Office of Archaeological Studies, Archaeology Notes 243. Museum of New Mexico, Santa Fe.
- Preucel, R.W.
- 1988 *Seasonal Agricultural Circulation and Residential Mobility: A Prehistoric Example from the Pajarito Plateau, New Mexico.* Unpublished Ph.D dissertation, Department of Anthropology, University of California, Los Angeles.
- Robinson, William J., Bruce G. Harrill and Richard L. Warren
- 1973 *Tree-Ring Dates From New Mexico J-K, P, V: Santa Fe-Pecos-Lincoln Areas.* Laboratory of Tree-Ring Research, University of Arizona, Tucson.
- Rose, Martin R., Jeffrey S. Dean, and William J. Robinson
- 1981 *The Past Climate of Arroyo Hondo, New Mexico, Reconstructed from Tree Rings.* Arroyo Hondo Archaeological Series 4. School of American Research, Santa Fe.
- Santa Fe Archaeological Society
- 1959 Unpublished Field Notes on LA 4. On File at the Archaeological Records Management Section, Historic Preservation Division, Santa Fe, New Mexico.
- Schutt, Jeanne A.
- 1983 *The Analysis of Formal Tools for NMAP Sites: New Methods of Data Retrieval.* In *Economy and Interaction along the Lower Chaco River*, edited by Patrick Hogan and Joseph C. Winter, pp.263-274. Office of Contract Archeology and Maxwell Museum of Anthropology, University of New Mexico, Albuquerque.
- Schlanger, Sarah H.
- 1988 Patterns of Population Movement and Long-Term Population Growth in Southwestern Colorado. *American Antiquity* 53(4):773-793.
- Shepard, Anna O.
- 1963 *Ceramics for the Archaeologist.* Publication 609 of the Carnegie Institution. Washington, D.C.
- Smiley, Terah L., Stanley A. Stubbs, and Bryant Bannister
- 1953 *A Foundation for the Dating of Some Late Archaeological Sits in the Rio Grande Area, New Mexico: Based on Studies in Tree-Ring Methods and Pottery Analysis.* Laboratory of Tree-Ring Research Bulletin No. 6. University of Arizona, Tucson.
- Stubbs, Stanley A., and W. S. Stallings, Jr.

1953 *The Excavation of Pindi Pueblo New Mexico*. Monographs of the School of American Research and the Laboratory of Anthropology No. 18, Santa Fe.

Traylor, Diane, and Robert P. Schafe

1982 Ceramics. In *Bandelier: Excavations in the Flood Pool of Cochiti Lake, New Mexico*, edited by L. Huebhel and D. Traylor, pp. 239-294. Submitted by National Park Service, Southwest Cultural Resource Center, to Interagency Archaeological Services Division. Denver: National Park Service.

Veneklasen, Gordon O.

1983 Ground Water Availability for Los Caballos de Santa Fe Subdivision Santa Fe County, New Mexico. Ms. on file at State Engineer's Office, Santa Fe, New Mexico.

Viklund, Lonyta, and Cherie L. Scheick

1989a *Cultural Resources Inventory Survey of a Proposed Housing Development East of the Eldorado Subdivision, Santa Fe County, New Mexico*. Southwest Report No. 224. Southwest Archaeological Consultants, Inc., Santa Fe, New Mexico.

1989b *Eldorado II: Cultural Resources Survey of Pueblo Alamo and Chamisa Locita Sustaining Area*. Southwest Report No. 230. Southwest Archaeological Consultants, Inc., Santa Fe.

Ware, John A.

1991 Archaeological Reconnaissance of the Arroyo Hondo Vistas Development, Santa Fe County, New Mexico. Ms. On file, Santa Fe County Land Office and Archaeological Records Management Section, Historic Preservation Division, Santa Fe, New Mexico.

Warren, A. Helene

1971 *Notes on the Geology and Resources of the Pueblo Alamo Area, San Sebastian, New Mexico. A Preliminary Report Relating to the Archaeological Salvage Program Conducted by the Museum of New Mexico, at Pueblo Alamo (LA 8), near San Sebastian, New Mexico*. Laboratory of Anthropology Note No. 67. Museum of New Mexico, Santa Fe.

1979 Geological and Mineral Resources of the Cochiti Reservoir Area. In *Archaeological Investigations in Cochiti Reservoir, New Mexico*, vol. 4: *Adaptive Change in the Northern Rio Grande Valley*, edited by J. V. Biella and R. C. Chapman, pp. 47-60. Office of Contract Archeology, University of New Mexico, Albuquerque.

1981 The Micaceous Pottery of the Rio Grande. In *Collected Papers in Honor of Eric Kellerman*, edited by A. H. Schroeder, pp. 148-166. Papers of the Archaeological Society 6. Archaeological Society Press, Albuquerque.

Wendorf, Fred

1953 *Salvage Archaeology in the Chama Valley, New Mexico*. School of American Research Monograph No.17. Santa Fe, New Mexico.

Wendorf, Fred, and Erik Reed

1955 An Alternative Reconstruction of Northern Rio Grande Prehistory. *El Palacio* 62:131-173.

Wilson, C. Dean, and Eric Blinman

1995 Changing Specialization of White Ware Manufacture. In *Ceramic Production in the American Southwest*, edited by B. J. Mills and P. L. Crown, pp. 63-87. The University of Arizona Press, Tucson.

Wiseman, Regge N.

1995 *The Belen Bridge Site and the Late Elmendorf Phase of Central New Mexico*. Office of Archaeological Studies, Archaeology Notes 137. Museum of New Mexico, Santa Fe.

1999 Tracking the Traffic: Plains Artifacts from a 13th-Century Pueblo near Santa Fe, New Mexico. In *La Frontera: Papers in Honor of Patrick H. Beckett*, edited by Meli Duran and Dave Kirkpatrick, pp. 231-240. Archaeological Society of New Mexico Publication 25. Albuquerque, New Mexico.

APPENDIX 1. GENERAL CHIPPED STONE ANALYTICAL METHODS by James Moore

Four classes of chipped stone artifacts were recognized: flakes, angular debris, cores, and formal tools. Flakes are debitage exhibiting one or more of the following characteristics: definable dorsal and ventral surfaces, bulb of percussion, and striking platform. Angular debris are debitage that lack these characteristics. Cores are nodules from which debitage have been struck, and on which three or more negative flake scars originating from one or more platforms are visible. Formal tools are artifacts that were intentionally altered to produce specific shapes or edge angles. Alterations take the form of unifacial or bifacial retouch, and artifacts are considered intentionally shaped when retouch scars obscure their original shape or significantly alter the angle of at least one edge. Informal tools were also recovered and are debitage that were used in various tasks without being purposely altered to produce specific shapes or edge angles. This class of tool is defined by the presence of marginal attrition caused by use. Evidence of informal use is divided into two general categories—wear and retouch. Retouch scars are 2 mm or more in length, while wear scars are less than 2 mm long.

Attributes recorded on all artifacts include material, amount of surface covered by cortex, portion, evidence of thermal alteration, edge damage, and dimensions. Platform information was recorded for flakes only.

Material type. This attribute was coded by gross category unless specific sources were identified. Codes are arranged so that major material groups fall into specific sequences of numbers, progressing from general material groups to specific named materials with known sources. The latter are given individual codes.

Material texture and quality. Texture is a subjective measure of grain size **within** rather than **across** material types. Within most materials texture is scaled from fine to coarse, with fine materials exhibiting the smallest grain sizes and coarse the largest. Obsidian is classified as glassy by default, and this category is applied to no other material. Quality records the presence of flaws that can affect flakeability, including crystalline inclusions, fossils, visible cracks (also called incipient fracture planes), and voids. Inclusions that would not affect flakeability, such as specks of different colored material or dendrites, are not considered flaws. These attributes were recorded together.

Artifact morphology and function. Two attributes are used to provide information about artifact form and use. The first is morphology, which categorizes artifacts by general form. The second is function, which categorizes artifacts by inferred use. These attributes were coded separately.

Cortex. Cortex is the chemically or mechanically weathered outer rind on nodules; it is often brittle and chalky and does not flake with the ease or predictability of unweathered material. For each artifact, the amount of cortical coverage was estimated and recorded in 10 percent increments.

Cortex type. The type of cortex present on an artifact can be a clue to its origin. Waterworn cortex indicates that a nodule was transported by water and that its source was probably a gravel or cobble bed. Nonwaterworn cortex suggests that a material was obtained where it outcrops naturally. Cortex type was identified, when possible, for any artifacts on which it was present.

Portion. All artifacts were coded as whole or fragmentary; when broken, the portion was recorded if it could be identified.

Flake platform. This attribute records the shape and any alterations to the striking platform on whole

flakes and proximal fragments.

Thermal alteration. Cherts can be modified by heating at high temperatures. This process can cause a realignment of the crystalline structure, and sometimes heals minor flaws like microcracks. Heat treatment can be difficult to detect unless mistakes are made. When present, the type and location of evidence for thermal alteration was recorded to determine whether an artifact was purposely altered.

Wear patterns. Use of a piece of debitage or core as an informal tool can result in edge damage, producing patterns of scars suggestive of the way in which it was used. Cultural edge damage denoting use as an informal tool was recorded and described when present on debitage. A separate series of codes was used to describe formal tool edges, allowing measurements for both categories of tools to be separated.

Edge angles. The angles of all modified informal and formal tool edges were measured; edges lacking cultural damage were not measured.

Dimensions. Maximum length, width, and thickness were measured for all artifacts. On angular debris and cores, length was the largest measurement, width was the longest dimension perpendicular to the length, and thickness was perpendicular to the width and was the smallest measurement. On flakes and formal tools length was the distance between the platform (proximal end) and termination (distal end), width was the distance between edges paralleling the length, and thickness was the distance between dorsal and ventral surfaces.

Flakes were divided into removals from cores and bifaces using a polythetic set of variables. This array of conditions models an idealized biface flake and includes data on platform morphology, shape, and earlier removals. The polythetic set used here was adapted from Acklen et al. (1983). In keeping with that model, when a flake met 70 percent of the listed conditions it was considered a removal from a biface. Instead of rigid definitions, the polythetic set provides a flexible means of categorizing flakes and helps account for some of the variability seen during experiments.

Whole Flakes

1. Platform:
 - a. has more than one facet
 - b. is modified (retouched and abraded)
2. Platform is lipped.
3. Platform angle is less than 45 degrees.
4. Dorsal scar orientation is:
 - a. parallel
 - b. multidirectional
 - c. opposing
5. Dorsal topography is regular.
6. Edge outline is even, or flake has a wasted appearance.
7. Flake is less than 5 mm thick.
8. Flake has a relatively even thickness from proximal to distal end.
9. Bulb of percussion is weak (diffuse).
10. There is a pronounced ventral curvature.

Broken Flakes or Flakes with Collapsed Platforms

1. Dorsal scar orientation is:
 - a. parallel
 - b. multidirectional
 - c. opposing
2. Dorsal topography is regular.
3. Edge outline is even.
4. Flake is less than 5 mm thick.
5. Flake has a relatively even thickness from proximal to distal end.
6. Bulb of percussion is weak.
7. There is a pronounced ventral curvature.

Artifact is a Biface Flake When:

-If whole it fulfills 7 of 10 attributes.

-If broken or platform is collapsed it fulfills 5 of 7 attributes.

Figure A 1. Polythetic set for distinguishing biface flakes from core flakes.

References Cited

Acklen, John C., et al.

1983 *Supplemental Inventory of 53 Prehistoric Archeological Sites for the Ute Mountain Land Exchange*. PNM Archeological Report No. 4 [Draft]. Public Service Company of New Mexico, Albuquerque.

Beckner, Morton

1959 *The Biological Way of Thought*. Columbia University, New York.

Office of Archaeological Studies

1994 *Standardized Lithic Artifact Analysis: Attributes and Variable Code Lists*. Office of Archaeological Studies, Archaeological Notes No. 24b. Museum of New Mexico, Santa Fe.

APPENDIX 2. CLAY SAMPLES COLLECTED FROM THE ELDORADO AREA

Sample #	Location	Natural Color	Refired Color
1	Ojo De Baca	5YR 4/6 Dark Reddish Brown	2.5YR 5/6
2	Roadcut by Lamy	5Y 6/3 Pale Olive (Greenish)	5YR 6/6
3	El Dorado Wilderness	5Y 8/6 Yellow	5YR 6/6
4	Ojo De Baca	10YR 7/2 Light Gray	2.5YR 6/6
5	Ojo De Baca	2.5YR 4/6 Dark Red	10R 4/8
6	El Dorado Wilderness	10YR 7/6 Yellow	10R 4/8
7	Canocito	10YR 7/1 Light Gray	7.5YR 7/6